

# GREEN Innovation



**YBTER**

(Young Business Technology & Entrepreneurial Researchers)

CONGRESS  
PROCEEDINGS  
2015 VOL-4

Association of Business Technology  
Department of Commerce & Financial Management (DCFM)  
University of Kelaniya



**YBTER 2015 Congress Proceedings**

**ISBN 978-955-0947-03-4**

Disclaimer

Responsibilities of the content of papers included in this publication remain with the respective authors. Editorial Board or YBTER have no responsibility over the content of individual articles.

© Copy Left Policy

**Young Business Technology and Entrepreneurial Researchers  
(YBTER)**

Department of Commerce and Financial Management  
Faculty of Commerce and Management Studies  
University of Kelaniya

**2015**

## Editorial Committee

C.N. Wickramasinghe, PhD  
MRKN Yatigammana, PhD  
L.C.H. Jayarathna  
H.A.Harshaka Hettiarachchi  
B.C.P. Jayarathna

## Supervision

Dr. C. Pathirawasam

Dr. D.M. Semasinghe	Mrs. S. Amaratunge
Mrs. G.K. Rathnayaka	Mrs. L.V.K. Jayathilaka
Dr. W.R.P.K. Fernando	Dr. S.M.A.K. Samarakoon
Mr. S.C. Thushara	Mrs. R. Gajanayaka
Mrs. S.A.C.L. Senarath	Mrs. W.A.D.S. Wijetunge
Ms. K.G.M. Nanayakkara	Mrs. N.L.E. Abeywardena
Mrs. P.M. Jeewandarage	Mr. S.A.R. Lasantha

Mr. D.M.N.S.W. Dissanayaka

## Preface

Young Business Technology & Entrepreneurial Researchers' Congress (YBTER) is an avenue that opens a world of researching and exploring novel & creative abilities of the undergraduates of Sri Lanka. The YBTER congress is organized by the Association of Business Technology (ABT) of the Department of the Commerce & Financial Management of the University of Kelaniya as an annual event since year 2012 and this year is the 4<sup>th</sup> edition of the event.

Theme of the year 2015 YBTER congress is "In search of new perspective in Green Innovations in Sri Lanka". The main focus of the congress is to recognize municipal and electronic solid waste as a resource rather than a problem. In general, waste always been treated as a problem. Therefore, many waste management techniques have been discovered to solve the problem. Yet, the problem is still existing and multiplied. Hence, the existing approaches of solving the problem of waste is not appropriate. Therefore, there is a need of new method/s of solving the problem of waste. In order recognize waste as a resource there should be innovative business avenues, which requires waste as raw material in their business process.

If the waste is treated as yet another raw material for the businesses, there are ample of opportunities are opened in the business world to develop new products using waste and market them to satisfy the need of the customers. The purpose of setting the said theme is to treat waste as a resource thus, create new business opportunities for waste which in turn satisfy the customer needs. Thus, the YBTER congress 2015 discourse a new approach to treat the waste as a resource for new business models. Even though the suggested business models might need further modifications, YBTER congress 2015, is a milestone of the university system in Sri Lanka, where it develops a new approach of treating for waste and develop innovative recycled products which holds a great potentiality of developing to marketable products.

**MRKN Yatigammana, PhD**

Editor in-Chief

B.Com (Business Technology) course coordinator

## Acknowledgements

YBTER Congress 2015 is another exclusive milestone of the Students Association of Business and Technology (ABT) of the Department of Commerce and Financial Management (DCFM), University of Kelaniya. It was a hard journey for us as we had to face enormous challenges on the way through. Yet, we have been able to surpass all those confrontations with the ones who helped us to drive its success for the 4<sup>th</sup> consecutive year. At this moment as a gratitude to them, we would like to highlight them since without them we won't be able to do such a great endeavor.

Our special honor goes to Dr. D.M. Semasinghe, the Dean of the Faculty of Commerce and Management Studies and Dr. C. Pathirawasam and Head of the Department of Commerce and Financial Management for always encouraging us. Also, our sincere gratitude goes to all the lecturers at the Department of Commerce and Financial Management for the invaluable support given. We would like to remind our valuable sponsor, Association of Accounting Technicians (AAT) Sri Lanka for the financial support extended. Further, we would like to remind the Works Department, University of Kelaniya for extending their support to make this endeavor a reality. Last but not the least we are thankful to all the undergraduates who actively participated in the event and for their contributions, commitment and enthusiasm to make YBTER Congress 2015 a success.

YBTER 2015 Organizing Committee

## Message from Dean



It gives me a great pleasure to convey this felicitation message as the Dean of the Faculty to the YBTER Congress 2015 organized by the Students Association of Business and Technology (ABT) of the Department of Commerce and Financial Management (DCFM). It is a richly deserved honor to greet them as they are celebrating a fruitful 4<sup>th</sup> consecutive year of YBTER. As always, this time ABT is heading the congress with an innovative theme named “Green Innovations: Resource Recovery and Reuse Business Models in Sri Lanka”. In fact, ABT is renowned for novel endeavors and the theme is more appealing for Sri Lankan and global context.

It is not a surprise that the world is curious about sustainable solutions to the proper waste management. I strongly believe this initiative may have a constructive impact on such annoying waste management problems in our pathway to be a self-sustaining country. Moreover, this as an undergraduate endeavor may certainly open up new avenues on contemporary topics such as Outcome Based Learning, Student Centric Learning that are apparently being talked about these days in Sri Lanka. I extend my sincere appreciation for such novel initiative with meticulous attention and I take this opportunity to wish all the success for this congress and its organizing committee and highly appreciate the effort made by the staff and students to make this event a success.

**Dr. D.M. Semasinghe**

Dean, Faculty of Commerce and Management Studies

## Message from Head



It is indeed an honor as the Head of the DCFM to convey my warm congratulation to the YBTER Congress 2015 at this occasion of its 4<sup>th</sup> consecutive celebration upon the theme “Green Innovations: Resource Recovery and Reuse Business Models in Sri Lanka”. Most importantly, it is my proud privilege to mention that this honor goes to the Students Association of Business and Technology (ABT) of the Department of Commerce and Financial Management (DCFM) as organizers of this event.

The world today needs people, especially young generation of exceptional caliber with brilliant minds. The concept by YBTER, I believe opening up new avenues on innovative open-minded learning, will pave the way towards much needed graduates fully fledged with the skills required to attend the issues confronted by public. Over the decades, the world has been struggling to find sustainable resource usage strategies. I highly appreciate this effort as it develops intellectual capabilities and unique skills that can shape our future minds.

I look forward to your continued participation in the process of novel initiatives and I'm delighted to extend my appreciation for the effort made by the staff and students to make this event a success.

**Dr. C. Pathirawasam**

Head, Department of Commerce and Financial Management

## Abbreviations

MOENR : Ministry of Environment and Natural Resources

MOLGPC : Ministry of Local Government and Provincial Councils

NSWMSC : National Solid Waste Management Support Centre

LLDF : Local Loans and Development Fund

SLILG : Sri Lankan Institute of Local Governance

UDA :Urban Development Authority

CEA :Central Environmental Authority

LA : Local Authority

SW: Solid Waste

MSW: Municipal Solid Waste

SWM :Solid Waste Management

MOHNW : Ministry of Health, Nutrition and Welfare

MC : Municipal Council

UC : Urban Council

PS : Pradeshiya Sabha

PHI : Public Health Inspector

PIC: Person In charge

RM: Recyclable Materials

IWMI : International Water Management Institute





## Table of Contents

Preface .....	iii
Message from Dean .....	v
Message from Head .....	vi
Abbreviations .....	vii
<b>Chapter 01: Introduction to Municipal Solid Waste and Sanitary Waste status in Sri Lanka .....</b>	<b>1</b>
Current State of Solid Waste Management .....	1
New Developments .....	4
Evolution of the MSW and SM Approaches .....	6
<b>Chapter 02: Solid waste Management and R<sup>3</sup> Business Climate in Sri Lanka .....</b>	<b>10</b>
Life cycle perspective of RRR business in Sri Lanka .....	12
RRR Front end supply chain: Solid Waste Management phase .....	14
RRR Back end Supply Chain .....	15
<b>Chapter 03: Generic R<sup>3</sup> Business models and cultivating “Business Perspective” .....</b>	<b>17</b>
R <sup>3</sup> approach as a way of Solid waste Management .....	17
R3 business Thinking Approach .....	19
Problem with current level of existing R3 Business models .....	22
Shifting from need based thinking to demand driven thinking .....	24
<b>Chapter 04: Innovative Products and Business Models .....</b>	<b>28</b>
Multitask Pen Holder .....	28
Gray Water Recycling System .....	35
Home Furifar .....	46
“Backspace” Basket Bottle Game .....	51
INNOTEC: Making furniture using E-waste .....	61
Products from waste CDs – ‘WEW Solutions’ .....	72
Coconut Shell Lamp Shade .....	80
<b>Chapter 05: Conclusion and Recommendations .....</b>	<b>87</b>
Recommendations for creating healthy Investment climate .....	88



## **Chapter 01: Introduction to Municipal Solid Waste and Sanitary Waste status in Sri Lanka**

Sri Lanka is an island nation in South Asia with a population of 21 million has shown drastic human and economic development in the last decade. After the conclusion of the long civil conflict lasted for nearly 30 years, Sri Lanka has given attention towards reaching higher economic, social and human development standards by year 2020<sup>1</sup>, it is seen that the country has achieved high human development than other neighboring countries in the region. Sri Lanka was placed at 73 out of 187 countries in Human Development Index in year 2014<sup>2</sup>. Most of the Millennium Development Goals have been achieved and with the end of thirty years long war more attention was given to infrastructure development in various areas<sup>3</sup>. In general health Standard of Sri Lanka had passed the South Asian level and reach to a competitive level with East Asian countries<sup>4</sup>. Although many diseases were properly controlled prevention from “dengue” fever has been an issue in Sri Lanka. Owing to improper dumping of waste it is very difficult to control the breeding and spreading of mosquitos. However, there are legislative policies and institutions which have been established to cultivate proper waste management mechanisms in Sri Lanka. These changes are reflected in the areas of Municipal Solid Waste Management (MSWM) and Septage Management (SM) where Resource Recovery and Reuse (RRR) initiatives are suggested at policy level over improper open dumping and landfilling.

### **Current State of Solid Waste Management**

The biggest problem in MSW aspect in Sri Lanka is finding up-to-date statistics about the SW in Sri Lanka. Only publically available document providing statistics about the solid waste in Sri Lanka is “Database of Municipal Solid Waste in Sri Lanka<sup>5</sup>” which had published in year 2005. Therefore statistics available for reference in

decision making are very much out dated (nearly by a decade). As a result the true picture of the MSWM and RRR business in current Sri Lanka cannot be seen in published statistics. However since there is no other alternative statistics of year 2005 have to be used as the latest available statistics of MSW in Sri Lanka.

According to the Table 1 Western province is responsible for more than one-half of waste production in the country. Colombo is the largest waste generating district, where it generates 44% of the total waste production in the country. Apart from Gampaha and Kandy all other districts contribute for less than 5% each for the total solid waste generation.

**Table 1: Contribution for Solid waste generation by District and Province in Sri Lanka**

Province	District	Gross weight of waste collected per day (Ton)	District percentage	Provincial total (Ton)	Provincial percentage All Island
Western	Colombo	1,257	44.3%	1,663	58.6%
	Gampaha	313	11.0%		
	Kalutara	93	3.3%		
Southern	Galle	103	3.6%	198	7.0%
	Matara	68	2.4%		
	Hambantota	28	1.0%		
Central	Kandy	145	5.1%	229	8.1%
	Matale	33	1.2%		
	Nuwara Eliya	51	1.8%		
Northwestern	Kurunegala	73	2.6%	170	6.0%
	Puttalam	97	3.4%		
Sabaragamuwa	Ratnapura	49	1.7%	92	3.2%
	Kegalle	43	1.5%		
Uva	Badulla	57	2.0%	86	3.0%
	Manaragala	29	1.0%		
North Central	Anuradhapura	52	1.8%	74	2.6%
	Polonnaruwa	22	0.8%		
Eastern	Ampara	57	2.0%	233	8.2%
	Batticaloa	119	4.2%		
	Trincomalee	56	2.0%		
Northern	Jaffna	71	2.5%	93	3.3%
	Mannar	4	0.1%		
	Kilinochchi	1	0.0%		
	Mullativu	9	0.3%		
	Vavuniya	9	0.3%		
<b>Total</b>		<b>2,838</b>	<b>100.0%</b>	<b>2,838</b>	<b>100.0%</b>

Source: Database of Municipal Solid Waste In Sri Lanka, 2005

In the general composition of the municipality waste, more than one-half of the solid waste contains bio degradable (short term) waste. Other waste such as paper, wooden, saw dust, long term bio degradable and polythene and plastics are at equal percentages (Figure 1).

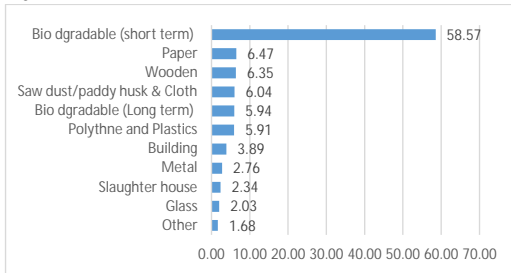

*Figure 1: Composition of municipal waste collection in Sri Lanka*

There are 18 municipal councils, 37 urban councils and 256 Pradeshiya Sabhas in Sri Lanka. According to the by-laws of the country these 311 LAs are primarily responsible for SWM within their locality. There are more than 8000 employees employed in SWM in LAs, where they are operating 172 special dumping trucks, 618 four wheeled tractors, 205 two wheeled tractors, 1152 hand carts and 83 other equipment for waste collection. In current practice higher percentage of bio-degradable solid waste are dumped openly in selected locations of the country. As the waste collection has become a social and environmental problem, other Resource Recovery and Reuse (RRR) options such as home composting, organic fertilizer making and bio gas generation have been identified as alternatives; however, open dumping has been the popular option in populated districts like Colombo. The Moon Plain landfill site which was established by JICA's cooperation in 2003 is an only landfill site in the country which has been issued the environmental clearance<sup>6</sup>.

Policy level attention on MSWM and SM has been drastically improved in last decade. National Solid Waste Policy, National Solid Waste Strategic Plan, National Policy on Water and Sanitation, National Cleaner Production Policy have been drafted and had implemented certain mechanisms as a measure taken for waste management in the country. Also there are other mechanisms which are planned to be implemented in near future. Institutions and projects like Pilisaruru project and Polythene and plastic recycling project by the Central Environment Authority (CEA), National Solid Waste Management Supporting Centre (NSWMSC), Western Province Waste Management Authority, and National Cleaner Production Centre have been working on the RRR aspect of MSWM. Further the Involvement and contribution of International Organizations, INGOs, NGOs and other community organizations and universities on Solid Waste and Septage Management has been increased in Sri Lanka throughout the last decade.

## **New Developments**

There is an increasing trend up to year 2007 and there were 12 composting facilities have been established by year 2013 (Figure 2). Significantly, there are more than 100 active composting facilities currently available in the country<sup>7</sup>.

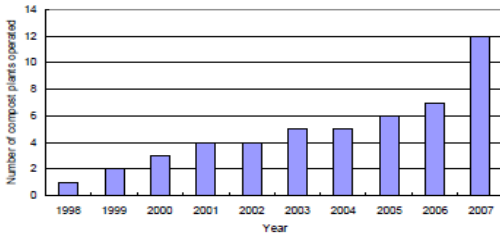

*Figure 2: Trend in compost plants in Sri Lanka*

MSWM had been drastically authorized in recent years and the sole responsibility of waste management was given to Local Authorities (LAs) by the legislations. However due to resources limitations they were unable to take the control over the MSWM totally. With the ongoing growth of the waste volume, public attention was given to health and safety issues with improper garbage dumping thorough the LAs, laws, regulations and institutions which had been established. Accordingly Sri Lanka's biggest dumping yard at Blumandal in Colombo has been abandoned of use for dumping. Changes in policies and legislations encourage home composting and "Polluter pays" policy. Hence, everyone who dumped their garbage could be charged a financial fee by the LAs. Since those changes cannot stop the waste generation rather than regulating, waste recycling facilities like Karadiyana-Colombo and Sundarapola-Kurunegala, proper dumping yards like Meethotamulla, safe landfilling sites like Puttalam had been established and it is proposed to establish at least one recycling facility for each district. Septage management has not been as issue in Sri Lanka since long time. As 92% of the households have access to universally accept improved sanitary facilities (Figure 3)<sup>8</sup> there was not much concern over sanitation facilities in the country. Access to Improved Sanitary facilities in Sri Lanka has increased at a higher rate compared South Asian countries and other countries in the world.



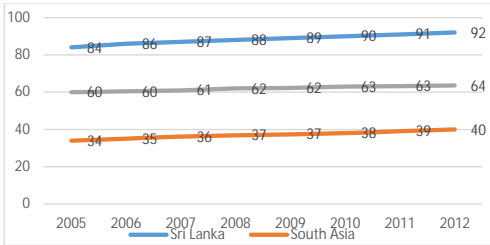

*Figure 3 Comparison of improved sanitary facilities of Sri Lanka with South Asia and World*

Source: Word Bank 2014<sup>9</sup>

According to the National Policy for Rural Water Supply and Sanitation Sector the basic Sanitation should ensure protection of both surface and ground water from pollution and the users from water borne diseases and other health hazards. Since traditional pit latrine have been recognized as an environmentally unfriendly solution; (i) Piped Sewer systems with treatment which meets recognized standards (ii) Septic Tanks with Soakage Pits (iii) Water Sealed Latrines with Disposal Pits and (iv) Any other technology acceptable to the health authorities have been proposed as solutions<sup>10</sup> for environmental friendly septic waste management. These changes demanded for septage management practices in Sri Lanka and some of the LAs have taken measures to develop sanitary waste treatment plants in their localities.

### **Evolution of the MSW and SM Approaches**

Municipality Solid Waste and Septage management has been the mostly discussed environmental issue at Local administrative level. Municipal Solid Waste Management (MSWM) and Septage Management(SM) seem to be challenging issues for most the Sri Lankan Municipalities with the rapid increase of population,

urbanization and industrialization. There are ample of resources available both online and offline for understanding SW, Septage, SWM, MSWM and SM<sup>11</sup>. However the evolution of approaches for MSWM and SM was hardly discussed. There are basically three approaches for addressing the MSW problem: SWM approach, RRR Approach and RRR Business thinking approach (Figure 4). Most of the available reports have discussed MSWM and SM within the given approach and its options. But there no holistic view about the three approaches was considered.

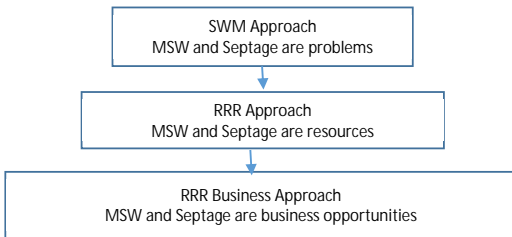

*Figure 4: Three approaches adopted in SWM*

There are number of options which were attempted solve SW and Septage problem in Sri Lanka since long time. The approaches adapted for solving waste problem were more focused on environmental and social concerns raised by waste collection. Municipal Council Ordinance and Urban Council Ordinance in Sri Lanka were the pioneering legislations attempted to give responsibility of handling MSW to local authorities. The principal aim of these legislations was to regulate municipal waste disposal while recognizing the solid waste management essentially as a local issue. At that time land space was not a big issue for waste dumping. Hence, even commercially valuable populated areas were able selected for open dumping of MSW and even septage disposal. Since there were limitations for open dumping and landfilling for a long

term with the increased volume of waste a problem solving approach was not recognized as the best approach to deal with the solid waste. Not only in Sri Lanka even in most of the developing countries disposal of waste in open dumping or use for land filling were identified as less effective ways of SWM<sup>12</sup>.

As a result of the recognition of limitations for open dumping and landfilling, attention had shifted towards Resource Recovery and Reuse (RRR) approach. In this approach waste generation was attempted to be reduced by encouraging effort for reduce, reuse, and recovery of resources from the waste. Even though the approach is relatively new for the Sri Lankan context, developed countries like USA have recognized RRR as a leading waste management mechanism in 1970s. They had introduced a Resource Recovery Act (RRA) in 1970 which aimed to increase federal involvement with management of solid waste, encouraged waste reduction and resource recovery and created national disposal criteria for hazardous waste<sup>13</sup>.

Most municipalities have started to use Municipal Solid Waste (MSW) for recycling and composting but septage was used mainly for the production of compost rather other options. Recent discussions of the municipalities, government and energy generating bodies had emphasized the feasibility of using MSW for power generation and septage as a land application for treatment at waste water plants or treatment at independent septage treatment plants. Although there were feasibility studies and pilot projects launched in many places in the country they were not successful as expected. As an example bio gas based electricity generation effort had started in 2009 at 'Narahenpita Jathika Pola', but the facility was totally abundant without using for another economically valuable purpose by 2014. Furthermore, the compost making effort at Meethotamulla dump yard has been stopped since a couple of years<sup>14</sup>. These failures have paved the path to inculcate business thinking approach

on RRR business where RRR should be considered as a business opportunity where income can be generated. With this approach more non-public sector involvement in SWM and SW is expected. This report will focus mainly on the attention towards RRR business thinking approach for SWM and SW in Sri Lanka

## Chapter 02: Solid waste Management and R<sup>3</sup> Business Climate in Sri Lanka

In order to investigate the investment climate on RRR, and even for proper identification of existing business models in RRR sector, supply chain of the RRR business should be identified. At different phases in the supply chain factors like size, scale and technology differ. Hence investment requirements too differ. The available sources of funding and the investment climates faced by the members of the RRR supply chain are not unique therefore. In order to carry out a convenient analysis of the supply chain, it can be divided in to two specific phases.

1. RRR Front end: Solid Waste Management phase
2. RRR Back end: Recycle business phase

So far the studies on SWM and RRR business in Sri Lanka have discussed the SWM or RRR business as a single unit. However, based on the activities, processes, human involvement and value addition RRR front end and back end supply chain are remarkably different. In order to understand the middle processors, it is very important to understand and analyze the RRR business supply chain separately as front end and back end (Figure 05).

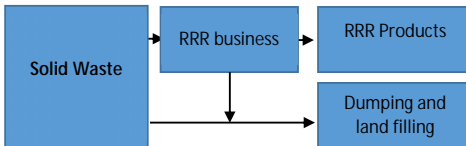

*Figure 5: Macro level picture of the RRR business life cycle*

Even though the SWM, Environmental and other policies, plans and legislations talk about building a relationship between solid waste and RRR business. The practical effort that needs to be put into the early stage of the waste preparation is not properly investigated. Lots of discussions are focused on end-to-end process, but not on the whole process that goes in-between. In order to make RRR products, RRR materials needed to be extracted from the solid waste. This is the most difficult and serious bottle neck in the RRR industry, as this is the phase where lot of human effort going into the process. Sanitary waste water management also comes under this level.

Front end supply chain of RRR business is largely related to SWM activities. It flows from waste generation to recovering of reusable and recyclable materials from waste. It contains the activities such as waste collection, storing, pre-processing and recovering of RRR outputs. Beginning from this stage value addition at each stage is not attractive to bring large number of private sector investors in to the business. However, these activities are unavoidable and low value added activities in RRR business process. Since majority of recyclers are product manufactures they are not interested in engaging in front end supply chain activities. Hence LAs, small and micro scale entrepreneurs become the nodes of the front end supply chain of RRR business. These members are relatively ill-treated when it comes to financial opportunities available for them.

Back end supply chain activities are the processes that convert recovered organic and recyclable materials into marketable products. Since the outcome products are selling to end users as final product the value addition of these activities are much higher. Hence, the attraction for this phase of the RRR supply chain is higher than the front end phase. Since more established companies are involved in final product manufacturing which uses recovered waste as raw materials, therefore more financial opportunities are available to the members of this end.

## **Life cycle perspective of RRR business in Sri Lanka**

The figure 02 illustrates the entities and processes involved in business perspective of RRR supply chain cycle specifically relating to Sri Lankan context. The arrows represent the processes involved and rectangles represents the entities involved. Round cornered rectangles represent the outputs of the processes. Each process can be considered as investment opportunity for establishing business entity related to the process in RRR business.

As can be seen in the schematic supply chain model, the back end of the supply chain is more congested with entities and processes related to the recycling, selling, export and import activities. Front-end activities are more or less at the responsibility of LAs and waste generators themselves to bring the MSW into RRR business process. Detailed illustration of both front-end and back-end supply chain entities and processes of RRR business depicted in figure 03 and 04.

Organic outcomes of the RRR process are mostly reused for composting and for a lesser extent use to make bio gas in Sri Lanka. Since there is an increasing demand for organic farming and organic foods there is a potential increase of demand for compost in the future. Recyclers are relatively well established medium or large scale manufacturers those who manufacture final product for consumption using recovered materials from waste as raw materials. By using recovered raw materials they expect to reduce the material cost and also the operation cost by using less energy usage. Hence, RRR businesses relating to recycling materials need to fulfil their requirements.

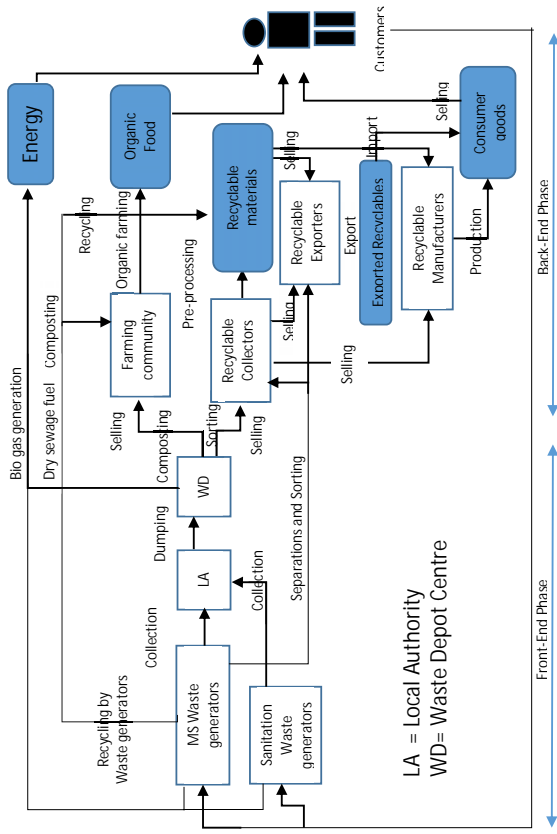

Figure 6: Life cycle analysis of the RRR business industry in Sri Lanka



## RRR Front end supply chain: Solid Waste Management phase

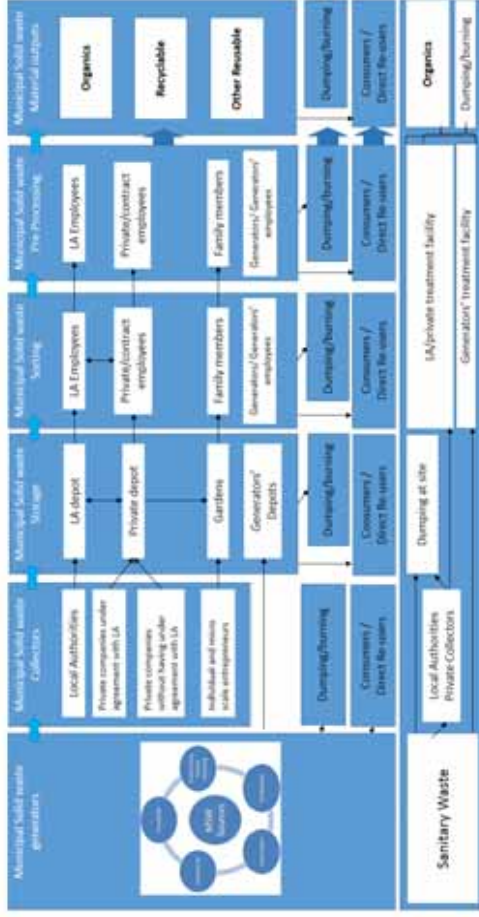

Figure 7: RRR Front end supply chain: Solid Waste Management

## RRR Back end Supply Chain

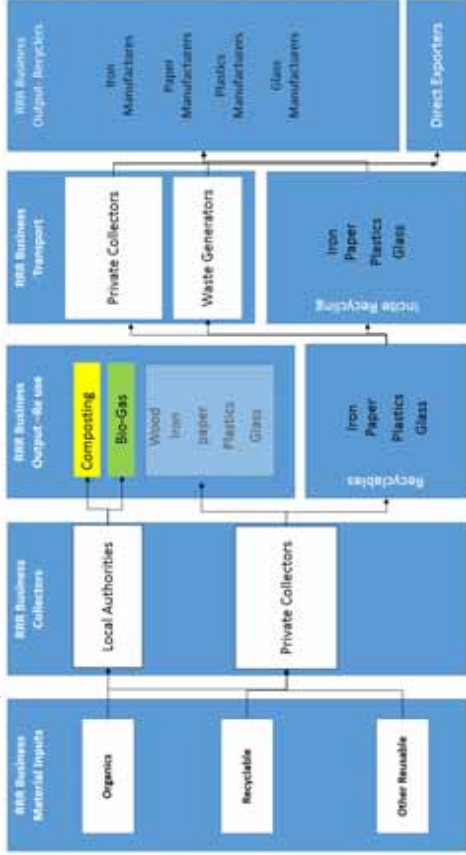

Figure 8: RRR business Back-end Supply Chain

So far the discussions on SWM and RRR business have been focused on environmental and socio-economical aspect of reduce, reuse and recycle of the scared resources. The basic philosophy of the discussions were reduction of cost in terms of economic, environmental and ecological perspectives. Hence, both business community and general public have not seen the income generating capacity of RRR business. Even private sector companies engaged in RRR industry consider it as part of their CSR, rather than as an avenue for earning income. The business awareness or business thinking of the general public and in RRR business is weak and thus the attraction especially for the first phase of the RRR supply chain is not visible. Furthermore, front end phase activities of the RRR business have been considered as a lower level jobs in Sri Lanka. Hence, willingness to start a business as waste collectors, to work as waste sorter or a transporter has a social resistance because of the lower social status given. Therefore RRR business tend to become a business where only uneducated hardcore poor people are involved. This lower level recognition has changed a bit for second or back process activities in RRR business. More reputed companies are engaged in recycling industry and most of the ISO certified companies are dealing with foreign clients.

## **Chapter 03: Generic R<sup>3</sup> Business models and cultivating “Business Perspective”**

RRR business in Sri Lanka is strongly connected with the Solid Waste Management strategy of the country. Municipal Solid Waste has been a problem for municipal areas since long time. With success stories in other parts of the world, RRR has been identified as one of the feasible solutions for Sri Lankan Solid Waste problem. When analyzing the related institutions at national, provincial and local authority policy level, their major focus is on solving the Solid waste problem. Therefore all the policies and legal frameworks they have developed and applied are taken the path of problem solving approach rather than RRR business opportunity creation approach. Thus continuation of policies from SWM to RRR business is missing in existing institutional structure.

### **R<sup>3</sup> approach as a way of Solid waste Management**

The figure 09 illustrates the entities and processes involved in life cycles perspective of RRR supply chain cycle specifically relating to Sri Lankan context. The arrows represent the processes involved and rectangles represents the entities involved. Round cornered rectangles represent the outputs of the processes. Dashed square represent the business boundary of GENERIC models which shows related entities and processes covered by the proposed business models.

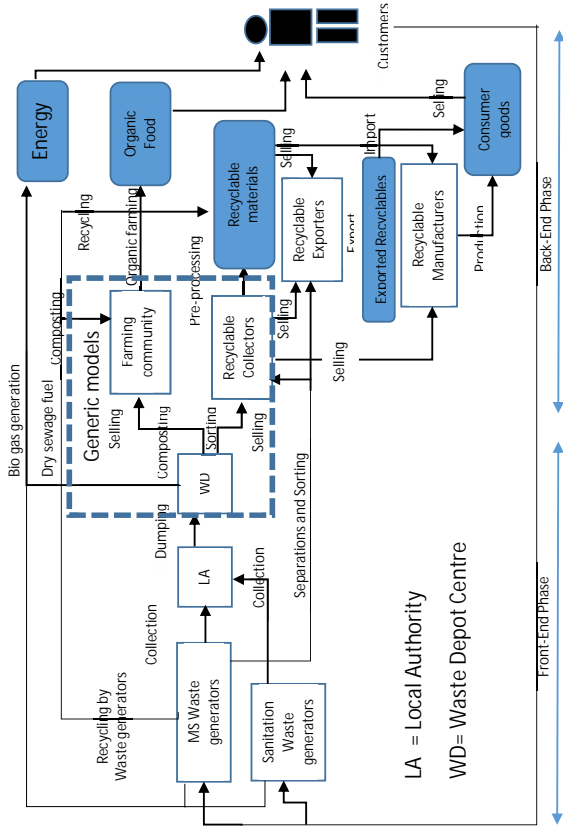

Figure 10: Position of generic business model in supply chain

Business boundaries of the GENERIC business models almost identical with the business model at Municipal council level. When it comes to life cycle of SW-RRR business supply chain, the GENERIC business models are focusing on unsorted organic waste collection, sorting, composting and selling of fertilizer and recovered Recyclables. Since there is no value addition on recyclable waste within the business models, opportunity for getting a higher price for pre-processed Recyclables have been ignored in GENERIC business models.

### **R3 business Thinking Approach**

As always in the business, the consumers are critical in RRR business, where they are ones who demand the final RRR products. When there is demand for final product, there is a potential business opportunity for RRR business. If there is no demand, unless demand can be generated in a cost effective manner, the RRR business initiatives would become a social service rather than a business.

So far RRR products promote with the individual social responsibility on environment. However, once the customer base is established, RRR or whatever business customers should be satisfied. When customer base is established majority of them would not be helping hands or buying RRR products as their social responsibility. They will be demanding customers. Eventually RRR businesses would become the members of another supply chain/s. So every player in RRR business has to be competitive and market oriented. However, there are no stakeholders who are involved in improving marketing aspect of RRR business end product as a competitive business (Figure 10)

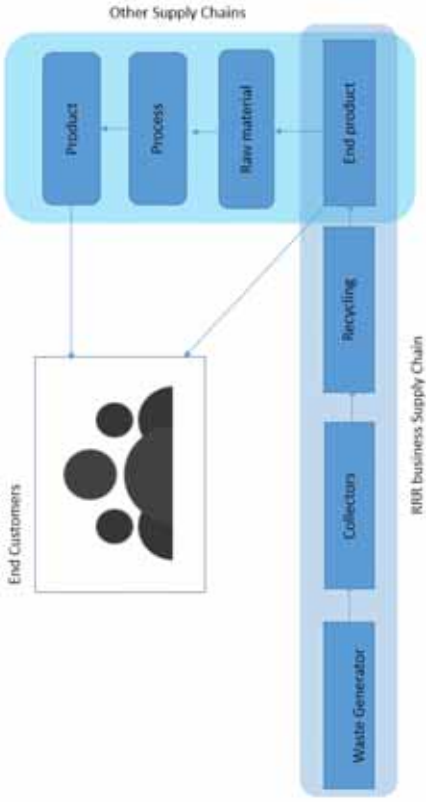

To be competitive and market driven RRR business, investment would be higher than the solid waste problem solving approach. Majority of the public owned re-cycling facilities are driven as foreign aided investments. Further, the members in RRR business also believe government and other agencies should provide them the financial aids and technology to carry out their business; however it is not the practical reality. Financial institutions such as banks do not have special loan scheme for RRR business. There are no other specific financial facilities available for RRR business. Further there is no attractive tax exceptions given to RRR business sector. Hence, the entering cost for RRR business is relatively high and since the payback period is long, new entrants would not be able to absorb the financial cost in a short run. Therefore, there is a tendency to shut down the operation within first two-three years. Hence, financial institutions should come up with loose conditioned financial facilities for RRR business sector, at least at the early stage of the industry.

International Water Management Institute (IWMI) is one of the pioneering organizations trying to cultivate business thinking on SWM and build generic R<sup>3</sup> business models especially for developing countries. When considering the existing business models and proposed generic models by their forthcoming publication "*Resource Recovery from Waste Business Models for Energy, Nutrients and Water Reuse*", they are positioned as the makers of organic fertilizer, bio gas and energy from high volume degradable waste, where there is no natural business demand exists in current Sri Lanka.

When creating *Business thinking*, it should consider the customers, market forces, demand and supply mechanism, profit making and private sector involvement in the process. However, the existing business models not seriously concern and discuss these elements in the models to be successful business solution in Sri Lankan context. Hence, GENERIC business models have proposed a solution



for a problem that has been a serious social concern in Sri Lanka, but the GENERIC business models seems to be a same treatment with different branding over the well-established social and environmental interests on solid waste management.

Even though there are health and other environmental concerns over usage of chemical fertilizers in farming, the Farmers are still concerning about getting higher harvest at low cost. Meanwhile the majority of the consumers are not willing to pay premium for organic products. Both these conditions not welcome the potential higher supply of organic fertilizer to the market. When it comes to bio gas and demand for bio energy source would be even worse, since there are efficiency issues relates to bio gas generation and energy creation. Therefore Viability of GENERIC models to reduce the burden of LA and other public institutions and attract private sector investment as business opportunity is seriously doubtful in the context of Sri Lanka.

### **Problem with current level of existing R3 Business models**

Business positioning of GENERIC business models in RRR business In Sri Lanka illustrates in the figure. As per the figure illustrate volume of the sanitary and wet degradable SW is much higher compared to other recyclables in Sri Lankan context. Hence, sanitary and degradable SW have always been a problem, where GENERIC business models can provide an acceptable solution. However, the products that can be made from these solid waste are obviously limited to compost, bio gas, and bio energy, which are not have established demand in Sri Lankan context. In the current context in Sri Lanka, majority of the degradable waste management projects are run either as home scale or large scale projects which are managed by public sector without having profit making intentions.

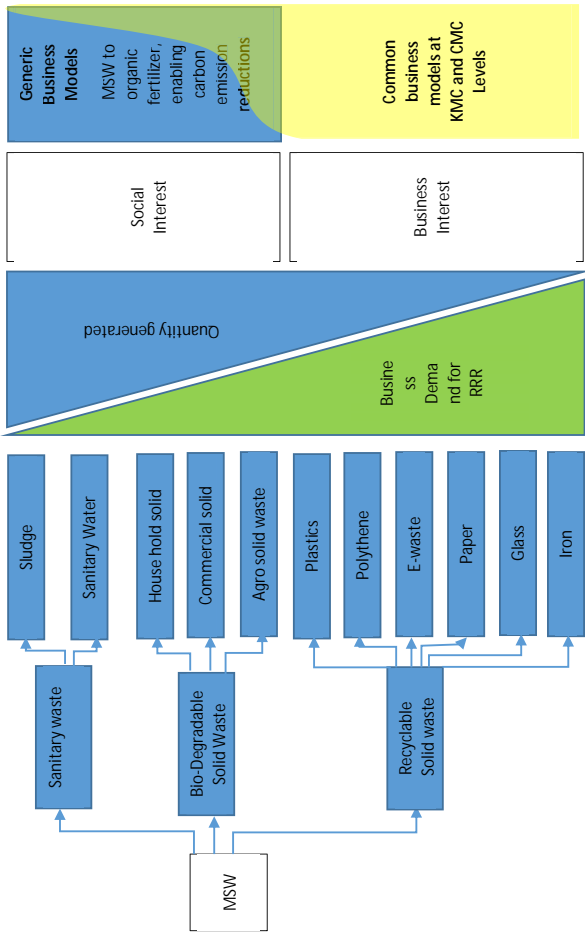

On the contrary recycling industry in Sri Lanka has establish quite strongly with public, private and public-private partnerships. Unlike organic fertilizers, bio gas and bio energy, use of recyclable waste in industrial production reduce the production cost and operation efficiencies in many industries. Not only has the local demanded, there is international demand for the recyclable waste that create high volume demand for Recyclables materials. Since the supply of recyclable waste is limited, there is excess demand for recyclable waste from the manufacturers and exporters, which determine a price that attract investors for RRR business.

### **Shifting from need based thinking to demand driven thinking**

Most of the published reports on SWM and RRR business in Sri Lanka has narrowed to analyze the institutional capacity, related policies and legislations and providing policy recommendations. The work so far done on the concept of business thinking give more attention on financial aspect of RRR. However, business or investment climate should be evaluated much more comprehensively than current practice.

Number of institutions, policies, plans, projects and legislations are there to establish sustainable SWM and RRR business in Sri Lanka, but none of them address the big picture of the supply chain. Investment climate should be analyzed according to its influence to both front and back ends of the supply chain. Further, broader level causes for existing investment climate should be investigated and it should not limited to analysis of financial aspect of the investment. However, discussions are yet to be gone towards all four basic economic factors; manpower, land, financial and entrepreneurship/business awareness/ recognition of RRR business in Sri Lanka. This study is taking the first step to analyze the investment climate for RRR business through the said four business pillars.

There are number of stakeholders directly and indirectly influenced and benefited from RRR business. However, their strategic objectives and action plans seems to be overlapping and redundant. Hence, in the process of establishing a mechanism to reduce the waste, there seems to be resource waste as well. Since most of the institutions established at least five years before thinking, there is a necessity to bring all the stakeholders together and overall their strategic plan which should align with business thinking rather than solid waste problem thinking. Approach should be shifted from need based or problem solving approach to business driven or demand driven thinking. Stakeholders need to think about new product lines that would attract modern customers than not just thinking on compost and bio gas. When the new products lines comes in to the industry, citizens as customers will demand more and that will pave the path for investors and entrepreneurs to come on board for RRR business. In order to achieve this paradigm shift following policy implications are recommended.

1. New integrated continuation of policies, legal framework and business friendly procedures from SWM to RRR business should be established. They should focus on RRR as a business opportunity rather than social solution for Solid Waste Management.
2. All the existing laws, policies, procedures relating to SWM and RRR business have not been updated at least for 5 years. When the RRR business psychology changes towards business thinking all the relevant laws, policies, procedures relating to SWM and RRR business should be revisited and revised.
3. Requirements of multiple institutions on SWM and RRR business at policy level should be revisited and single apex body which is responsible for all the related activities in SWM and RRR businesses in Sri Lanka should established.

4. There should be data audit at least for every two year. Databases on SWM and RRR business should be maintained and all the updated statistics, performance indicators should be publically available.
5. RRR business incubation center/s should be established. The business knowledge and guidance required by the RRR business owners should be provided. This incubation center should nurture the startup RRR businesses until they can survive themselves.
6. Consortia of Waste recyclers are essential elements in RRR business. There should be common forums where all the business stakeholders can come together and solve their problem with common agreement.
7. Apart from identifying the RRR business models, possible RRR business supply chains should be identified. Business model/s focus more on individual business but each RRR business will become a member of a bigger supply chain. Therefore recognizing RRR supply chains too are essential in RRR business thinking.
8. Dedicated financial facility mechanism for RRR businesses should be established. RRR business should be treated as a special form of business than other type of business that requires financial facilities with relatively unfastened conditions.
9. Last but not least, business thinking requires all the stakeholders to think about the customers first. They should provide what customers want rather than providing what they can offer. Hence R & D activities should be encouraged frequently to

innovate new lines of products that can attract new customers to RRR businesses.

## Chapter 04: Innovative Products and Business Models

### Multitask Pen Holder

by

*K.M.S.K.Kulathunga, Supun Weragoda, Thiwanka Liyange ,  
Madhawa De Silva, Tharindu Chinthaka, K.D.Sandeepa, G.D.  
Abhayarathne, G.P. Holipitiya, I.K.A.H.E. Kodithuwakku, D.D.  
Fonseka, D.T. Gunasekara and G.L.S.Dayan*

### ***Introduction***

Since wastes pollute the environment, it affects not only human but also animals, trees, water, air and basically the entire environment. Therefore, effective waste management has become very important in today's world. Thus, people have focused on converting waste materials or used products into new materials or products of better quality or for better environmental value.

Wastes come from different sources; solid wastes, liquid wastes, hazardous wastes, organic wastes, bio chemical wastes, industrial sources of wastes, agricultural wastes etc.

These different types of wastes can be harmful to the environment if they are not properly disposed. Therefore, waste disposal has become a major issue at present. To solve this, the concept of Reduce, Reuse, and Recovery (3R) has emerged as a solution to manage wastes.

Reduce is decreasing the sources of wastes or eliminating wastes. Reuse is to use an item again after it has been used. This includes conventional reuse where the item is used again for the same function, and new-life reuse where it is used for a different function. In contrast, recycling is the breaking down of the used item into raw materials which are used to make new items. Sometimes the production process allows useful materials to be passed on as environmental waste. One example would be the chemicals used in

printing. These can be recovered from the waste stream and used again in production.

By making a new product from waste, a new business opportunity can be created and same time it will satisfy a need in the market.

### ***The Problem***

A large number of marker pens are thrown away from the schools, univetsites and other institutions every year. As a result metal, chemicals and plastic waste ending up in landfilling. Refillable marker pens are not always refilled and throw away after using onetime. Therefore. In any organization, disposing marker pens are a serious environmental problems.

We might not pay much attention to this in detail but we probably have a few pencils and pens on our desk that we always move from one place to another and always stumble upon. It would be much easier if we get something to store them in and can make our desk much more organized.

### ***Product Concept***

Used marker pens & carbon pens are converted into a useful pen holder to solve the above problems. This is **multitask pen holder** that's been made from marker pens that are thrown away. This can be used not only to hold pens and pencils but to charge the phone as well. This new pen holder consists of different phone charger ports, a key holder and a table lamp. The used marker pens are now reused to get many tasks done.



## ***Product Design***

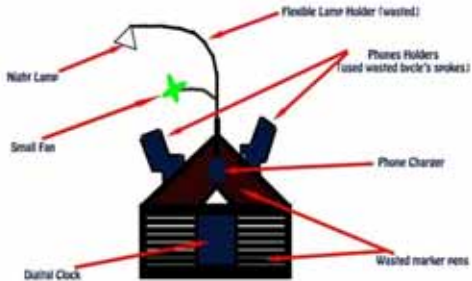

## ***Product Development Process***

1. Collecting the needed materials
  - a. Collecting of all used marker pens from the Department of Commerce and the Financial Management of the University of Kelaniya and also from private institutes and tuition classes that are situated around the University.
  - b. Collecting of used bicycle spokes and used lamps.
  - c. Getting provided with glue, baby ribbons, digital clock, charger and others needful.
2. Product making process
  - a. Making the basement of the pen holder by using used marker pens and glue.
  - b. Making the phone holders using bicycle spokes and baby ribbons
  - c. Fixing the night lamp and fan
  - d. Fixing the digital clock
  - e. Connecting the phone charger
  - f. Painting and finishing



## **Business Model**

### ***Key partners***

Universities, tuition classes and schools are our key suppliers. Marker pens are used more commonly in these places. So we can collect used marker pens easily from these places.

### ***Key activities***

Since this is an innovative product, the production platform is important. The designing of the product and making it are the key activities. We should ensure about the quality and the final look of the product.

### ***Key resources***

Key resources of this product are used marker pens, bicycle spokes and charger ports, a clock and the lamp for the table lamp. And also the idea is considered as a key resource.

### ***Value propositions***

The multi usage of the product is very convenient to the user. So the performance and the convenient are our value propositions. And also reduction of plastic and metal wastes is also focused as a value proposition.

### ***Customer relationships***

We need to talk to customers personally and should do direct sales with our target customer segment. So personal selling is the way of keeping customer relationships and once the product is successful with promotion, we look forward to put the product to the market focusing our target audience.

### ***Customer segment***

We've basically focused on school students, undergraduates and also teachers and clerical staff in offices to sell our product.

### **Revenue streams**

Basically revenue is targeted from direct sales.

### **Cost Structure**

Production and packaging are the costs we should bear mainly.

### **Business Model Canvas**

<b>Key Partners</b>	<b>Key Activities</b>	<b>Value Proposition</b>	<b>Customer Relationships</b>	<b>Customer Segments</b>
Universities , tuition classes and schools are our key suppliers	The designing of the product and making it are the key activities.	The multi usage of the product.  The performance and the convenience.  Reduction of plastic and metal wastes.	Talking to customers personally and doing direct sales.	School students Undergraduates Teachers Clerical staff in offices
	<b>Key Resources</b>  Used marker pens, bicycle spokes and charger ports, a clock and the lamp for the table lamp.		<b>Channels</b>  Retail Social media Direct production experience	
<b>Cost Structure</b>  Production packaging		<b>Revenue Streams</b>  From sales of the product.		

### ***Business Risk Involved***

Though this idea is innovative to the current segment, this can be replicated. And also some technical issues may occur when coming to the phone charging facility. Health and safety risks are very low and there are no political and regulatory risks.

### ***Conclusion***

Plastic wastes are a problem to the environment. Disposal of used marker pens which are made of plastic and metal is a problem. The Multi task pen holder is a good solution to the disposal of used marker pens. It helps to keep the environment clean and reduces the pollution also.

It is also helpful to do multiple tasks using one equipment. The pens can be gathered to a place in a tidy way and also the phone can be kept nearby when charging. The lamp is also useful when studying on a table. So it is useful and convenient to the user.

The multi task pen holder is a good business opportunity as well. Comparing to the cost we bear, the revenue which can be earned will be good.

## **Gray Water Recycling System**

*by*

*K.S.H.Sarathchandra, G.M.T.N.Piyasekara, K.D.S.P. Imalka, M.T.M. Silva, U.V.G.A.U. Wickramarathne*

### ***Introduction***

Water is vital for all aspects of life, where it becomes a basic need for human survival. Only two and half percent of all water in the world is usable where remaining water is in the oceans. Also only one percent of usable water is accessible for extraction and use. Not only that the global population is expected to exceed nine billion people by 2050. Major growth will take place in developing countries, particularly in urban areas that already have inadequate wastewater infrastructure.

On the other hand, at the beginning of the 21st century, the world faces a water crisis, both of quantity and quality, caused by continuous population growth, industrialization, food production practices, increased living standards and poor water usage strategies. Wastewater management has a direct impact on the biological diversity of aquatic ecosystems, disrupting the fundamental integrity of our life support systems, on which a wide range of sectors from urban development to food production and industry depend. It is essential that wastewater management is considered as part of integrated, ecosystem-based management that operates across sectors and borders, freshwater and marine.

The use of wastewater for a variety of purposes is gaining increased attractiveness as a means of preserving scarce freshwater resources.

### ***What is gray water?***

There are several definitions for gray water in the literature. One such definition is that wastewater from washing machines, washing bowls, showers, bath tubes, cleaning containing mainly detergents. (Wilderer, 2003).



### *Calculating wastewater volume*

Approximately gray water comprises 50-80% of residential wastewater. About one third of the domestic wastewater consists of black-water and the other two thirds of gray water. Gray water compared to black-water, contains less nutrients. The following table indicates the approximate amount of wastewater produced by one person each day in an average home.

**Table 1: Average household wastewater production**

Wastewater type	Wastewater source	L/person/day	
Black water	Toilet	20	
Gray water	Shower	63	
	Hand basin	06	
	Washing machine	13	
	Laundry tap	02	84
Other waste water	Kitchen tap	12	
	Dishwasher	05	
<b>Total gray water</b>		<b>84</b>	
<b>Total waste water</b>			<b>121</b>

If gray water recycling properly done, has a great potential as alternative water source for purposes such as irrigation, toilet flushing and others.

### ***The concept***

Water scarcity, inappropriate sanitation and wastewater pollution are critically important global issues. Over half the world's population faces water scarcity. And mainly freshwater scarcity is a reality in many regions of the world today. Also the financial, environmental and social costs are projected to increase dramatically unless wastewater management receives urgent attention.

No matter how scarce or abundant fresh water is, it is used for daily household activities and when after the usage it becomes wastewater. The best example is toilet flushing. Even though there are different low-volume flush toilets currently available that can be used with as little as 3 L of water per flush, normally most of the modern toilets use 6 to 9 L per one flush. And in some cases, the volume of water used per flush is not enough to empty the bowl and consequently, the user has to flush two or more times to adequately clean the bowl. In those cases a lot of fresh and clean water will be wasted.

Therefore, one major problem which should gain more and more attention is to avoid or reduce the usage of clean water for toilet flushing. And another issue of gray water management especially in developing countries is improper wastewater management which is one of the most important causes for environmental pollution and fatal diseases. Addressing these issues, gray water recycling system is introduced to the society.

### ***How it works***

Gray water is easier to treat and recycle than black water (sewage), because of lower levels of contaminants. Gray water (waste water from baths, bathroom sinks and washing machine) from the home will initially be gravitated to the underground **septic tank** via a **bar**



**screen chamber.** Wastewater from kitchens will be passed to a separate pit and not to this gray water collecting tank. Then gray water can be diverted either by gravity or by using a pump. A gravity system or the pump can only be used when there is sufficient fall from the laundry/bathroom drain to the surge tank and the septic tank should also have a trapped overflow.

Diversion of gray water for toilet flushing can be done very easily because in a house there is enough gray water will be collected in a septic tank which can be used for toilet flushing. But before releasing the gray water in the septic tank to the piston of the toilet it should go through a gray water filter system, since gray water should be treated to reduce harmful bacteria to an acceptable level to use it for toilet flushing.

Treatment of gray water may include: filtering (removing chemicals), settlement of solids and flotation and separation of lighter solids.

### Simple Water Filtering Machine

The figure shows a simple type of homemade water filter where gray water will be filtered to avoid blocking the system. In a simple filtration device such as this, gray water is discharged into a tank containing the filter material such as gravel, sand and mainly activated carbon.



The water flows continuously through the filter and directly to the piston of the toilet. Gray water filters will need to be replaced

from time to time, and the solids that settle on top of the gray water must be removed regularly.

Activated carbon can be shown as the main material in the filtering machine in the system. Activated carbon is charcoal that has been treated with oxygen to open up millions of tiny pores between the carbon atoms. Activated carbon surface properties are both hydrophobic and oleophilic; that is, they "hate" water but "love" oil. When flow conditions are suitable, dissolved chemicals in water flowing over the carbon surface "stick" to the carbon in a thin film while the water passes on. This process is called adsorption. As a result of the adsorption process, activated carbon is an effective method in removing chlorine and its by-products (THM's) and volatile organic compounds (carbon based VOC's). Therefore because of these qualities in activated carbon (effective and reliable in removing impurities), it is used as the main material for this filter system.

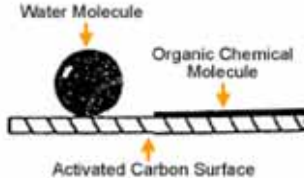

### *Diversion of gray water for irrigation*

There will be excess water store in the septic tank other than for toilet flushing which can divert for irrigation too. Also the gray water which is available in a house will not contain that much of chemicals and waste materials since this system only collect bathroom, and laundry water. So to be used for irrigation purposes, the septic tank can fix a fine net with a thin layer of activated carbon which will

absorb all the chemicals and waste materials. Because gray water used for irrigation should be filtered as it still contains high levels of solids and is otherwise it is possible to clog the irrigation system. Here also the net with activated carbon should replace time to time.

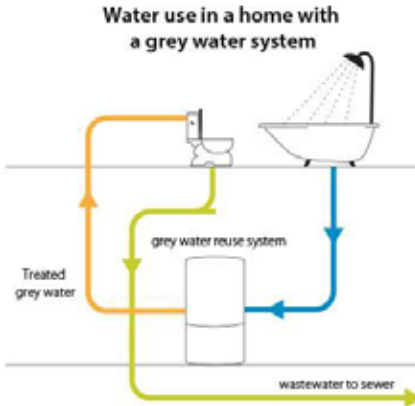

The WEW Solutions will create customized gray water filters according to customer requirements. Then customers will use those filters and after a particular time period the replacement of filters should be done. So customers can contact WEW Solutions and can replace their gray water recycling filter.

## ***Business Model***

### **Customer Segments**

To build an effective business model, a company must identify which customers to be served. Various sets of customers can be segmented based on the different needs and attributes to ensure appropriate implementation of corporate strategy. WEW's customer segment is a mass market which consist of each and every household customers. And this mass market can be divided in to two main categories as water users from their own water systems (wells) and water users from the municipal council water system.

### **Value Proposition**

Value proposition canvas make explicit how you're creating value for customer and help to design product and services customer want.

WEW Solution offer unique value to their customer through gray water recycling system. Our customers face two main problems of gray water disposal and increasing water and electricity bill.

As a solution for these issues WEW Solution has come up with this innovative and eco-friendly recycling system. Here all the household customers have taken as the target audience because each and every customer is facing problems in regard to the wastage of fresh clean water as well as the cost incurred due to that. So this is an innovative product as well as very useful to the target audience.

### **Channels**

There are 5 phases of channels in the gray water recycling system.

- Awareness: We can create awareness about this gray water recycling system by marketing this product as an eco-friendly solution and as well as a beneficial product to customers.
- Purchase: This will be based on direct marketing using our sales force.

- **Delivery:** We deliver the filter to our customer to their door step.
- **After sales:** We provide post purchase customer support through maintenance, and replacement of filters also can be purchase from us.

### **Customer Relationships**

We keep customer relationships while doing sales and as well as after sales. Because this is one of the most important factor since in order to make customized water recycling filters and to replace filters, long customer relationship is needed.

### **Revenue Streams**

Revenue is generated by selling the customized gray water filter machine and replacing old filters. That's will be the main income source.

### **Key Resources**

**Technological proficiency:** Innovative knowledge of the undergraduates, guidance and assistance of lecturers of the Department of Commerce and Financial Management and technological and expertise knowledge from outside parties (plumbers and engineers).

**Financial assistance:** From the Department funds for the initial development of the product prototype.

### **Key Activities**

- Idea generation
- Feasibility Study
- Sketching the basic structure
- Purchasing materials
- Develop the product
- Initial test run
- Selling and distributing
- Creating the network with customers

### **Key Partnerships**

- Engineer who assists with the prototype

The structure of the prototype and the appropriate places of the parts are decided by the engineer.

- Technician who assist with the filter

In order to make filter precisely (in terms of quantity of materials) we get technology know how from third party.

- Householders

This product is holding a significant importance in waste water management and this is very useful to each and every household customers since every person uses more and more water per day and it produce more and more gray water.

- Environmental authority

Since this is an innovative product which helps to manage and dispose waste water in a positive way (by reducing, recycling and reusing), we can build up a good partnership with the Environmental authority by promoting this product as eco-friendly.

### **Cost structure**

This describes the most important monetary significances when we are building our gray water recycling system.

- Material cost

Materials are the most important category in gray water recycling system. Because the main part of recycling system is gray water filter. In order to make customized gray water filters WEW Solution should incur variable material cost.

- Labor cost

As undergraduate in commerce stream we don't have proficiency knowledge regarding this filter system and technical expertise knowledge to build up the prototype of gray water recycling system. So we have hired a technical assistant from outside parties and which was incurred as the labour cost.

- Transportation cost

Material transportation cost and finished product prototype transport cost are the main two transportation cost.

***The Business Model Canvas***

<b><i>Key Partners</i></b>  Engineer Technician/  plumber  House holders  Environmental authority	<b><i>Key Activities</i></b>  Idea generation Feasibility Study Sketching the basic structure Purchasing materials  Develop the product Initial test run Selling and distributing Creating the network with customers	<b><i>Value Proposition</i></b>  Fulfilling the basic requirement house holders.  Uniqueness  Eco-friendly tool	<b><i>Customer Relationships</i></b>  After sales facilities	<b><i>Customer Segment</i></b>  Mass market (each and every householders)
	<b><i>Key Resources</i></b>  Technological proficiency  Financial assistance		<b><i>Channels</i></b>  Direct Marketing	
<b><i>Cost Structure</i></b>  <ul style="list-style-type: none"> <li>• Material cost</li> <li>• Labor cost</li> <li>• Transport cost</li> </ul>			<b><i>Revenue Streams</i></b>  <ul style="list-style-type: none"> <li>• Selling gray water recycling system</li> <li>• After sales services ( replacement of filters)</li> </ul>	

### ***Risk and issues***

- **Lack of awareness among householders**  
Proper awareness & introductions need to be given to motivate people to use this filtering system as it is new to the people.
- **Probability of acceptance from target customers**  
If customers do not get a proper idea about WEW Solutions they may refuse to use this and it will reduce the demand of WEW Solutions.
- **Finding difficulties when customizing the filter system**  
WEW Solutions provide a customized filtering system and when customizing, many other problems may arise such as finding places to purchase filters, connect filter system to toilet flushing piston etc.



## **Home Furfar**

by

*K.M.S.K.Kulathunga, Supun Weragoda, Thiwanka Liyange ,  
Madhawa De Silva, Tharindu Chinthaka, K.D.Sandeepa, G.D.  
Abhayarathne, G.P. Holipitiya, I.K.A.H.E. Kodithuwakku, D.D.  
Fonseka, D.T. Gunasekara and G.L.S.Dayan*

### ***The Problem***

Water is always been treated as a scarce resources. This problem has become severe mainly in urban areas of the world and majority of the people spend more time to search fresh water for their essential activities.

Therefore, we have come up with a solution of cleaning the unclean water into usable state through a filtering process. Thus, a water cleaning filter is developed.

### ***Concept***

Reusing and recycling alternative water supplies is a key part of reducing the pressure on our water resources and the environment. It is better to reduce water use and avoid generating wastewater in the first place, than to have to identify alternative water supplies and reuse options.

Recycling wastewater can ease the pressure on our water resources and avoid the need to discharge wastewater to the environment. Recycling wastewater can provide water that, with some management controls, is suitable for a wide range of uses including irrigation and toilet flushing.

### ***Product Format***

There are three similar sized pipes in the Filter. The Filter has the following layers starting from up to clean waste water.

1. Sponge
2. Sand
3. Shingle (big)
4. Shingle (small)
5. Active Carbon
6. Chip Stones
7. Sponge

A water pipe is connected with the domestic water system to collect waste water from wash room and the kitchen. A strainer is attached to the sink in the kitchen to collect particles and materials in waste water. The pipe is connected with the filter which is placed outside the house.

Wastewater is pumped to the pipes of the filter one by one. Once the first pipe is filled, water is pumped to the second one and when the second one is filled then to the third one. Wastewater flows through the above mentioned layers of the filter and filtered through out this process.

The filtered water then can be collected to a tank and finally can be used to the plantations and also can be used for flushing, cleaning and vehicle washing purposes.

### ***Product Making Process***

1. Collecting the needed materials

Collecting all sand, shingle (big), shingle (small), chip stones from the natural environment and sponge take from the hardware shop. As well as buying activated carbon from company who make activated carbon.

## 2. Product making process

It is not complicated product making process. First of all made a plan how to make filter and where it paste in house.

- Collected all material and brought those to one place.
- Cut necessary PVCs according to plan.
- Filled all layers one by one bottom to top
- Finally set other piece of PVSS on the top



### ***Business Model***

### **Key partners**

Sponge and active carbon are taken from hardware shops and other every material is taken from the natural environment.

### **Key activities**

Since this is an innovative product, the production platform is important. The designing of the product and making it are the key activities. We should ensure about the quality and the final look of the product.

### **Key resources**

Key resources of this product are used sponge, active carbon, sand, shingle (big), shingle (small). And also the idea is considered as a key resource.

### **Value propositions**

The usage of the product is very convenient to the user. So the performance and the convenience are our value propositions.

### **Customer relationships**

With our product and the target customer segment, we need to talk to customers personally and should do direct sales. So personal selling is the way of keeping customer relationships. And once the product is successful with promotion, we look forward to put the product to the market focusing our target audience.

### **Customer segment**

We've basically focused on schools, companies, universities and houses to product segment.

### **Revenue streams**

Basically revenue is targeted from sales by direct sales.

### **Cost Structure**

Production and packaging are the costs we should bear mainly.

### The Business Model Canvas

<p><b>Key Partners</b></p> <p>Hard wares and the natural environment As well as Company who make Activated carbon</p>	<p><b>Key Activities</b></p> <p>The designing of the product and making it are the key activities.</p>	<p><b>Value Proposition</b></p> <p>The performance and the convenience.  Re use the water and try to obtain multi tasks from the waste water.</p>	<p><b>Customer Relationships</b></p> <p>Talking to customers personally and doing direct sales.  Putting the product to the market focusing the TG.</p>	<p><b>Customer Segments</b></p> <p>Schools Houses  Hospitals Companies</p>
<p><b>Cost Structure</b></p> <p>Production Packaging</p>	<p><b>Key Resources</b></p> <p>Used active carbon, sponge, sand, shingle(big), Shingle (small), chip stones.</p>		<p><b>Channels</b></p> <p>Retail Social media  Direct production experience</p>	
			<p><b>Revenue Streams</b></p> <p>From sales of the product.</p>	

#### Business Risk Involved

Though this idea is innovative to the current segment, this can be replicated. These layers should be updated continuously, specifically active carbon.

## **"Backspace" Basket Bottle Game**

by

*H.R.L. Perera, K.T.J.C.M Perera, L.N.S. Perera, A.R Silva, R.P.E.K Rajapaksha, R.S Ranwala , G.K.S Nimeshi, W.N.N. Gunawardana, M.A.S.Y Gunarathne*

### ***Introduction***

Nowadays plastic consumption has increased due to the easiness of using them but disposing plastic is not such easy process. It is harmful to the environment if plastics are thrown away without disposing them. In order to minimize that harmful situation we thought to come up with a solution that will stimulate people to collect plastic instead of throwing them out.

There are some advantages of recycling plastic other than environmental protection. Those are,

- saves energy
- reduces landfills
- preserves our resources and protects wildlife
- good for the economy
- helps our climate problems

Therefore, our new product helps to collect used plastic bottles for the purpose of recycling. Due to the entertainment feature of this product we hope people will like to come to this machine and put plastic bottles. So after collecting them, our customers (plastic recycling companies) can recycle those bottles and can have above mentioned advantages of recycling.

### ***The concept***

This product is basically produced to collect plastics bottles which can be recycled later. To encourage people to participate in plastic bottle collection enthusiastically, we use sound and lighting system to this machine. Those lighting system and the sound system will entertain people. Fun and enjoyment is the easiest way to change the people's behavior. With reference to that theory we are going to

change the people's behavior to collect plastic bottles rather than throwing them out,

"Backspace" Basket Bottle game is a plastic bottle collector bin. The intention is to motivate people specially kids to recycle plastic bottles.

### ***How it works***

The bottles need to be thrown over the transparent panel to the basket. If you miss the target, it will slide back to you. If you hit the target the bottle will go through the tunnel which will trigger the switch.

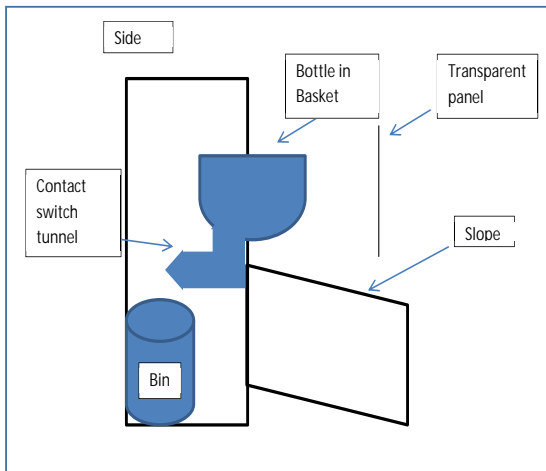

To make it more interesting you have to put 3 bottles on target. If the effort succeeds, within 20 seconds lights and sound effects will entertain you.

### ***Appearance of the Machine***

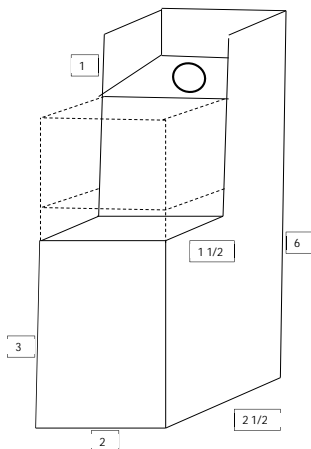

### ***The Mechanism***

Machine is on standby mode until a person presses the start button. When start button is pressed the LCD panel will give the quick instructions. When the bottle is put into the bucket it will go through a tunnel. In the middle of the tunnel, there is a touch switch which counts the number of bottles. Number of bottles collected and time (20 seconds) count down are shown on LCD panel. Lights and sound effects will entertain every successful throw. All activities are programmed into a circuit which acts as the heart of the machine.

The body of the machine is made out of galvanized sheets which enhances the durability indoors as well as outdoors. The slope brings back the target missed bottles back to the player. Pictures around the machine attract the users to use the machine. Outer cover can be also rent out for display of advertisements.



### ***The Business Process***

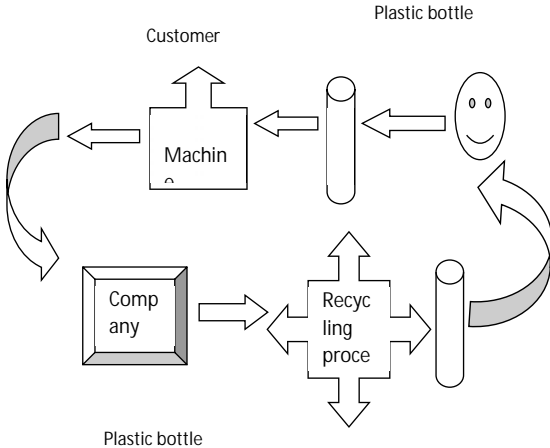

Customer will take bottles and put them in to the collecting machine. Then machine will store the bottles and once the machine is full, the recycling company will collect those bottles from the machine. Then by recycling those collected bottles they will produce a new bottle or other products. Again customer will buy that recycled bottle from the market and after using it, they will take them to the machine.

### ***Business Model***

#### **Customer Segments**

Customer Segments in a business canvas model means, identifying which customers it tries to serve. Various sets of customers can be segmented based on the different needs and attributes to ensure appropriate implementation of corporate strategy meets the characteristics of selected group of clients.

Our customer segment is a niche market which is going to be Plastic recycling companies. Currently plastic recycling companies are in a situation, where they don't receive enough plastic materials to do the recycling process efficiently. Our main motive is to cater to this problem faced by these companies by delivering them plastic bottles which will be collected through this machine.

Plastic recycling company's target market is going to be mainly schools and universities. Other than these they can place this machine at special events such as cricket matches, fairs, carnivals and festivals etc. near food outlets where lot of plastic bottles being disposed heavily.

### ***Value Proposition***

The value that we deliver to our customers is very unique. It will be greatly assist the plastic recycling companies to continue the recycling process without any interruption. Because via this machine we are helping our target customer to collect their necessary input smoothly.

The problem which is faced by our customers is that they are not getting enough plastic bottles to be recycled. Therefore as a solution for this issue, we have come up with this innovative idea as a great solution which is capable of bringing positive results to the environment as well as the customers by adding value to their business. So this machine is a kind of an entertainment tool as well, where the target audience is inspired to put any kind of plastic bottles by indirectly helping towards the recycling process of companies.

The customer that we are going to satisfy is very conscious about the environment. Our target audience is very much concerned about the nature or the environment and they are working hard to reduce the improper plastic disposal by motivating the people to dispose them in a healthy way which leads to create a positive impact in the environment.

If we justify why our target audience should purchase the machine from us, is due to the fact that we are offering this machine to match with their basic requirement, that is plastic (raw material) which is

the main input in their recycling process and we are the only one who offers this kind of product to the market. This is innovative rather than being imitative. So the quality of "Newness" is almost added to satisfy our target audience.

### ***Channels***

Our main channel of distribution will be the vendor machine. There are 5 phases of channels.

- Awareness: We can create awareness about this vending machine by marketing this product as an environmental friendly one which can be used to have a plastic free environment.
- Evaluation: Customer can directly collect the plastic bottles without getting mixed with other types of waste.
- Purchase: This will be based on direct marketing using our sales force.
- Delivery: We deliver the machine to our customer to their door step.
- After sales: We provide post purchase customer support through maintenance, 3 months warranty and user guidance materials.

### ***Customer Relationships***

We are planning to maintain long term customer relationships with plastic recycling companies through providing them after sales facilities, and also finding locations to place the machine and gain benefits from it. For example, building the network with schools, universities etc.

### ***Revenue Streams***

Revenue is generated by selling the plastic bottle collecting vendor machine. That's our main income source of our product. Not only there are many other ways to generate revenue too.

Brokerage fee: Charging a commission on introducing new customers to the plastic recycling companies.

Advertising: We can charge a fee for displaying advertisements as stickers on the outer cover of the vendor machine.

### ***Key Resources***

Technological knowhow: Innovative knowledge of undergraduates, guidance and assistance of lecturers of the Department of Commerce and Financial Management.

Financial assistance: From the Department funds for the initial development of the product.

### ***Key Activities***

- Research and development
- Designing the product
- Feasibility Study
- Purchasing materials
- Making the product
- Initial test run
- Selling and distributing
- Creating the network with customers

### ***Key Partnerships***

- Engineer who assists with the circuit

Inside of this machine there are many small circuits. To program those circuits as we wanted, we had collaboration with Engineers. They identified our basic requirements and came up with an attractive sound system and codes of programming.

- Technician who assist with the frame  
Frame of the machine should be durable and more attractive. For that we had to get technology know how from third party.
- Schools and universities  
This can be very useful if this machine is located at schools and university premises. Because a lot of consumers of plastic

bottles consumption can be seen with soft drinks and with water as well.

- Environmental authority  
This product very much supportive in terms of promoting green innovation in the current business activities, since it's an innovative product which helps to manage and dispose waste in a positive way (by reducing, recycling and reusing), we can build up a good partnership with Environmental authority by promoting this product as eco- friendly. And also there is high possibility of obtaining patent rights for this product as well.

### ***Cost structure***

This describes the most important monetary consequences while we are constructing our vendor machine.

- Material cost

Materials are the most expensive part of our production. Actually it is a variable Cost. This cost depends on the amount of machines that we are willing to produce going forward with our business. Since we are acting as Cost-Drivers, we focus on minimizing all costs which end results in adding more value to this commercial product. Under this, costs for circuits are very important. Because considerable amount of money are spent on purchasing the circuits.

- Labor cost

Since we are undergraduates of commerce stream, we are not much good at technological side. Therefore to overcome this issue, (lack of technical skills and knowledge) and to get technology know how we had to incur a cost on outsourced labor. Not only that, the body or the outer cover of the machine is also made with the assistance of some labors who should be paid.

- Transport cost

Material transportation cost and finished product transport cost are the main two transport cost.

***The Business Model Canvas***

<i>Key Partners</i>  Engineer Technician Schools and universities Environmental authority	<i>Key Activities</i>  Research and development Designing the product Feasibility Study Purchasing materials Making the product Initial test run Selling and distributing Creating the network with customers	<i>Value Proposition</i>  Fulfilling the basic requirement of plastic recycling companies  Uniqueness  Environmental tool	<i>Customer Relationships</i>  After sales facilities finding locations to place the machine	<i>Customer Segments</i>  Plastic recycling companies
	<i>Key Resources</i>  Technological knowhow Financial assistance		<i>Channels</i>  Machine Direct Marketing	
<i>Cost Structure</i>  Material cost Labor cost Transport cost		<i>Revenue Streams</i>  Selling vendor machine Brokerage fee Advertising		

**Risk and issues**

- Lack of awareness among plastic consumers  
 Proper awareness & introductions need to be given to motivate people to use this machine as it is new to people.

- Need of regular maintenance  
Maintenance needed as there are sensitive electronic parts involved in this machine. To mitigate this risk the circuit need to be sealed protecting it from water.
- Limited space to locate the machine in some public places  
The machine requires a space more than a normal bin. But by making it skinny and tall, the problem can be solved and also it ease the handling.

## **INNOTEC: Making furniture using E-waste**

by

*A.R.P. Jinadasa, E.W.A.Thashani, E.K.P.Bhagya, A.H.N.N.,  
Chathurangani, H.A.T.M. Tissera, K.P.W.Karunanayaka,  
B.V.N.madushani.G.A.S.P.Sandeepani, R.G.P.Indrachapa.*

### ***Introduction***

E waste or Waste Electrical and Electronic Equipment (WEEE) is the term used to describe old, end-of-life or discarded appliances using electricity. It includes computers, consumer electronics, refrigerators etc .which have been disposed by their original users.

"E-waste" is used as a generic term embracing all types of waste containing electrically powered components. E-Waste contains both valuable materials as well as hazardous materials which require special handling and recycling methods. This guide covers all categories of e-waste but emphasizes categories which contain problematic, scarce and valuable as well as interesting materials. Examples: Computers, LCD / CRT screens, cooling appliances, mobile phones, etc., which contain precious metals, flame retarded plastics, CFC foams and many other substances.

In Sri Lanka, dumping of e-wastes increasing rapidly. Therefore, e-waste collection centers are establishing in several places. But they are not tending to produce newest or innovative things. Thus, little concern is paid on what happen to the obsolete or damaged equipment which are no longer in usable state only.

According to 2010 statistics of Sri Lankan Customs, the average useful life times and forecasted growth rate of electronic items in next couple of years are mentioned in the following table. These details are only of the items which are legally imported to the country. In practical scenario, these figures could be larger than this.



With these figures, we can get an idea about the amount of e-waste generated in one year.

Item	PC	Printer	TV	Mobile Phones	IT machines	Refrigerators	Public City Machines	Washing Machines	Batteries
Annual Imports	300,000	130,000	400,000	1,200,000	40,000	250,000	4,000	70,000	6,000,000
Forecasted Growth Rate	12%	7%	7%	40%	5%	5%	4%	8%	1%



Source: statistics of Sri Lankan Customs, 2010

### *The INNOTEC concept*

INNOTEC is a set of innovative products from waste of electronic items under concept of “Green Innovation” introduced by the undergraduates of university of Kelaniya which provides solutions for the waste management. INNOTEC brand produces coffee tables, discussion tables, Cd racks, jewelry boxes and clocks as a solution for the increasing electronic waste in Sri Lanka. As a sample, university electronic waste collection is initiated for the innovation of electronic waste.

INNOTEC mainly concern about recycling electronic waste only which are generating within the university premises. Three innovative products are introducing based on the concept of RRR as a solution for the electronic waste.

### *Business Process*

INNOTEC innovates four household products which are recycled by waste of electronics. The core of this products are based on the computer parts which are collected from the university premises.

While developing these products, the collected parts are sorted and removed the unnecessary parts. After recognizing the customer requirements cutting, shaping, welding and fixing are completed by a technician. Then the product is decorated to add value for the finished product. Coffee table, CD holder, jewelry box and discussion table are the final products of this process.

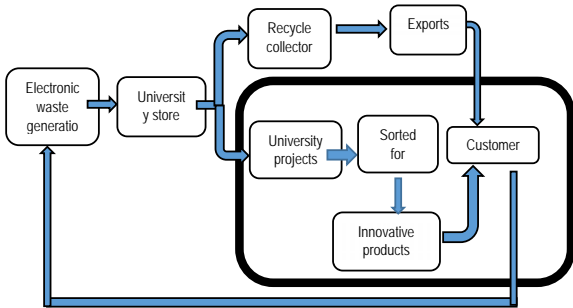

### ***Solution for E waste (INNOTEC PRODUCTION)***

#### **Coffee Table**

Coffee table is designed by using two desktop systems unit casing. After removing unwanted parts, they fixed with one another using nuts and bolts. Square shape glass is used for table surface. Glass sticker is



creatively designed to make the table attractive. This table can be used to serve cups of coffee for visitors while chatting. This coffee table can easily move and portable.

### **Jewelry box**

Jewelry box is created by using one UPS after removing the inside parts of the UPS. Then the three boxes are fitted together. These three boxes act as drawers. It can be customized to store earrings, bangles, and necklace separately. Customer can store large amount of jewelry in one unit. Also it is attractive.



### **CD Holder**

Mini CD Holder is one of the newest household furniture item in Sri Lanka and it was developed by using discrete computer system unit and clippers. The CD holder was partitioned into three parts and the user can use those as customized their preferences such as movies, music programs etc. Around 100 CDs can be put on and that could be held vertically or horizontally in flat surface. Also it can be hanged on the wall. The advantage of this CD holder is, CDs can be stored in safe manner with its paper or polythene cover that will help to avoid the CD damage when storing



and using. Further, the computer users could recycle their discrete system unit as usable item.

### **Discussion Table**

Discussion table is more popular and creative design since it targets niche market. This table is created by using two desktop system unit's casings, one glass and four thread bars. Four tread bars set on the two System Units and build up creative table with sculpture sticker on the surface glass. It improves the attractiveness of the table. The main advantage of the discussion table is, it can be easily set up on any time, for multiple purposes such as a reading table, to keep things etc.



### ***Business Model for INNOTECH Furniture***

#### **Discussion Table**

##### **1. Customer Segments**

###### **Discussion table**

Since there is a big problem in the E waste, we have designed the discussion table using E waste named as INNOTECH table by giving special focus to use in the offices. Therefore, our niche market would be the office people. We hope to sell our product to office bearers and hope it will have more demand since it is cheaper and creative than the tables currently available in the market.

### **CD rack**

Since we are living in information era lot of people use CDs and DVDs for collecting, storing and disseminating of data and information. This may include films, songs or any other entertainment things. Therefore, CD rack is produced targeting offices to store backups and other essential and important things. Also this product targets the ordinary people who use CDs and DVDs. Therefore we produce this for mass market.

### **Coffee table**

INNOTEC's main concern is reusing e-waste since it is a big issue to the environment. As a solution for increasing e-waste, we introduced INNOTEC coffee table using disposed system unit casings. We mainly focus on various customer segmentation. So our INNOTEC coffee table is not limiting to specific market, it can be used for hotels, restaurants, office and homes.

### **Jewelry box**

The jewelry box made by e-waste (UPS casing) is a product for house holders who come under the segmented market because the product is used by ladies to keep them orderly and safe.

## **2. Value Proposition**

### **Discussion table**

Newness – The discussion table represents the customer newness since it can easily move, adjust and environmental friendly. And also it is made by using waste materials.

Performance –this table is helping the customer get certain jobs done as it is not too heavy. It is very creative and attractive. This table can be offered similar value at a lower price.

### **CD rack**

INNOTECH CD rack is novel to the market since it has separated racks / covers for movies, music and other purposes according to customer preference. And also customer can store the variety of CDs in the one place with better arrangement. It can offer to the customer with a low price. This is easily movable and can be kept on the table.

#### **Coffee table**

INNOTECH Coffee table focuses on people who expect creative and innovative products. This product has many of interested characteristics as newness, environmental friendly, easily adjustable, movable, and not much heavy, price effective and multiple uses.

#### **Jewelry box**

Jewelry box is also made by e-waste. Therefore, the price of the product is low than the similar products in the market and also it's a user friendly because the product is creative and attractive to the customer segment.

### **3. Channels**

We can increase the awareness of our products through web sales, Salesforce and direct sales. We advertise our products on the websites, social media channels and hope to allow the customers to purchase the product through online. We can provide after sales service also. Direct sales force can be used to communicate and sell the products. First we make awareness to the people about over INNOTECH products through the social media, advertising. Since the product is new to the market, we can access to the customer through web sales, sales force and such traditional marketing activities.

And also we can interact our target customers using web sales by video content & pictures via Facebook, twitter, e-mails, web banners same as sales force and direct sales for partners.

#### **4. Customer Relationship**

Since customer is the key element, we have to build a good relationship with the customer by allowing them to call us, email us, and by giving personal assistance to get the information. Customers are provided the facility of giving their comments about the products. For that we hope to build a customer e-mail system and short message system to build long term relationship with each customers.

Personnel assistance and personnel selling is best ways to build up a good customer relationship with customer, because the products are new to the market. And social media advertising is also good communication method to attract new customers.

#### **5. Revenue Stream**

Main revenue model would be assets sale and advertising. In asset sales, we are selling ownership rights to the physical products.

Revenue streams are created using usage fee, subscription fee, brokerage fee, advertising fee, license fee. Our coffee table price is bearable price for target customers.

The product is selling to the end user and accordingly the revenue can generated through selling the product and advertising income from the web site which we can use for the product promotion. This is the good revenue method because our products are made by using waste items which we only incur zero cost to earn more profits.

#### **6. Key Resources**

Our physical key resource would be e-waste. All our products are made by using e-waste. We should have the financial resources also to produce our products. Not only that Intellectual knowledge, brand and other capabilities are also been advantages for our products to be commercialized.

The physical resources include two system unit cases, glass, sticker, wooden fittings and other tools such as nuts and bolts. Human

resources include people who helped to develop our products such as external technician, financial supporter and creative designer.

#### **7. Key Activities**

Key activities include recognizing e-waste in the university premises and collecting them. Then searching ways of creating new products using collected e-wastes and deciding the products which can be produced by making use of them. After deciding the products, purchasing whatever supported material and producing the products with the help of technicians whenever wanted. After finalizing the products next focus is to carry out other activities of 4Ps as price, place and promotion.

#### **8. Key Partnerships**

Our key suppliers are e-waste collecting places in university premises. Therefore, we have big support from the university administration (Internal audit division), ICT center and working division. We mainly gained raw materials from them. And also the other key suppliers are works department of university of Kelaniya, Glass cutting centers, external technician and other stakeholders.

#### **9. Cost Structure**

The main cost for these products are processing service charge and cost for other secondary raw materials. In addition we have to bear the variable and labor cost as our main cost streams. We can minimize our cost because of using e-wastes.

INNOTECH products comes under the cost driven approach and minimizing cost wherever possible. Therefore it is possible to make higher profits.



The Business Model Canvas of Total INNOTECH Products.

<p><b>Key Partners</b></p> <ul style="list-style-type: none"> <li>- Work division</li> <li>- University administration</li> <li>- External technical parties</li> </ul>	<p><b>Key Activities</b></p> <p><b>Recognizing e-waste</b></p> <ul style="list-style-type: none"> <li>- Collecting e-waste</li> <li>- Searching ways of producing</li> <li>- Deciding products to be produced</li> <li>- Producing and pricing</li> <li>- Promotion</li> </ul>	<p><b>Value Proposition</b></p> <ul style="list-style-type: none"> <li>- Attractive design</li> <li>- Easily movable</li> <li>- Reasonable price</li> <li>- Easily set up</li> <li>- Customization</li> <li>- Newness</li> </ul>	<p><b>Customer Relationships</b></p> <p><b>Personal Assistance</b></p> <ul style="list-style-type: none"> <li>- Dedicated Personal Assistance ( Discussion Table &amp; Coffee table)</li> <li>- Communities ( jewelry box &amp; CD rack)</li> </ul>	<p><b>Customer Segments</b></p> <ul style="list-style-type: none"> <li>- Officers &amp; Intellectual (Discussion Table)</li> <li>- Household &amp; Restaurant( Coffee table)</li> <li>- Ladies (jewelry box)</li> <li>- Household &amp; Office (CD rack)</li> </ul>
<p><b>Key Resources</b></p> <p><b>physical resources</b></p> <ul style="list-style-type: none"> <li>- Financial resources</li> <li>- Human Resources</li> </ul>	<p><b>Channels</b></p> <ul style="list-style-type: none"> <li>- <b>Direct Sales</b></li> <li>- <b>Dedicated Direct Sales</b></li> </ul>			
<p><b>Cost Structure</b></p> <ul style="list-style-type: none"> <li>- Raw materials</li> <li>- Machine &amp; equipment</li> <li>- Technician fee</li> </ul>		<p><b>Revenue Streams</b></p> <ul style="list-style-type: none"> <li>- <b>Assets sales</b></li> <li>- <b>Advertising</b></li> </ul>		

## ***Business Risks***

### **Market Risk:**

Though this product is an innovative recycled product, the customers are not concern about that but only concern about is that to fulfill their requirement. Therefore there is a high market risk

### **Competition Risk:**

There is no any reputed electronic waste recycling company in Sri Lanka. Hence the competition risk is low.

### **Technology Risk:**

As a developing country Sri Lanka is having a low level of technological capacity for the innovative product development. And also the technology may be rapidly changing therefore the products may have a risk of technologically outdated.

### **Financial Risk:**

Since these products are innovative the investors have to bare a high risk. Therefore the investors are not much willing to invest and that will cause to high financial risk.

### **Safety, Environment and Health Risk:**

Risk of safety, environment and health is low due to waste are reused and recycled to produce the products.

### **Replication potential:**

There is a high risk of replication, because of growing amount of electronic waste in Sri Lanka. That will be encourage the new enters to the market.

## **Products from waste CDs – ‘WEW Solutions’**

by

*K.S.H.Sarathchandra, G.M.T.N.Piyasekara, K.D.S.P. Imalka, M.T.M. Silva,*

*U.V.G.A.U. Wickramarathne*

### ***Introduction***

Electronic waste is one of the fastest growing contribution to our waste stream. As more and more outdated electronic equipment ends up in landfill, the negative impacts of e-waste on the environment and humans will increase.

Electronic waste or e-waste is a term for electronic products that have become unwanted, non-working or obsolete, and have essentially reached the end of their useful life. Because technology advances at such a high rate, many electronic devices become “trash” after a few short years of use. In fact, whole categories of old electronic items contribute to e-waste such as VCRs being replaced by DVD players, and DVD players are replaced by Blu-ray players. E-waste is created from anything electronic: computers, monitors, mobile phones, PDAs, VCRs, CD players, fax machines, printers, etc.

Electronics contain hazardous and toxic and when disposed- off in landfill, toxic chemicals from the e-waste seep into the ground leaving contaminated water and soil which remains in soil forever, endangering human life and other living beings.

Handing over to scrapers would end up in only benefit them by removing the re-usable components and the balance ending up in landfills. Further the health risk and manual injuries are caused to people who haven’t the knowledge to deal with e-waste and don’t adhere to disposal procedures.

There are 20–50 million tons of e-waste generated worldwide every year. But approximately only 11% of e-waste is recycled. Dumping of used CD’s has been a problem since 1999’s. Currently there’s no such proper solution to dumping the CD’s into the environment. So it is the responsibility on everyone who generates e waste to dispose them in a safe manner.

### ***What makes up e-waste?***

	<b>E Waste composition</b>
monitors	10%
televisions	10%
computers, telephones, fax	15%
DVD,VCR players, CD	15%
refrigerators	20%
washing machines      dryers,vacume	
cleaners	30%

*Source- EMPA Swiss Federal Laboratories for materials testing and research (definition according to the European Union WEEE Directive)*

### ***The concept***

Nowadays the usage of CD's is becoming less because the access to the internet has greatly increased in the past decade. These days, more and more people are able to access the internet from the comfort of their own homes.

As another effort WEW Solutions, we introduced 3 products from waste CDs with no cost to the environment.

Although it is unavoidable for electronic equipment to eventually become redundant, WEW Solutions follow the tips on minimizing the impact from household or office e-waste on the environment. There are most types of e-waste contain many valuable resources that can be recovered and reused and much less energy is needed to recover these resources than to produce new materials.

### ***How it works***

- CD Spindle Earring Stand

CD Spindle Earring Stand is a product which is made of useless CD's. This is another solution to reduce the electronic waste. The product

is cost effective, eye catching and impressive thing is only the electronic waste is included.

***Benefits of this product***

- Cost effective
- Reduction of e-waste.
- Innovative.
- Easy to use.



- ***Lampshade using CD's***

This Lampshade is a product which is made by useless CD's and the useless glass bottle. Two waste materials are been used for this product. This is an impressive, creative and useful solution for CD waste as well as for glass bottle waste. By adding some features for this, it has been created a big value. LED bulbs are used for this product to generate lightning. More lightning can be generated by 25W from this product. By using this product, we can **reduce** the electronic usage and it impacts to decrease electronic bill, **reuse** the CD's and glass bottles, and **recycle** the e-waste and the glass bottle waste.



- Magazine holder using CD's

The product which is created using useless CD's and the useless cardboard. This is useful for offices and households to keep the newspapers and magazines. This innovative product is zero costing. This is another e-cycle product which is solution for the reduction of CD's waste.

The WEW Solutions will design the various products (three e-cycle products) using cd's. Those are CD Spindle Earring Stand , Magazine holder using CD's, Lampshade using CD's.

### ***Business Model***

#### **Customer Segments**

To build an effective business model, a company must identify which customers it tries to serve. Various sets of customers can be segmented based on the different needs and attributes to ensure appropriate implementation of corporate strategy meets the characteristics of selected group of clients.

Our customer segment is a mass market. WEW will provide useful home appliance to the customers.

### **Value Proposition**

Value proposition canvas make explicit how you're creating value for customer and help to design product and services customer want. WEW Solution will offer unexpected range of products by using disposal CDs. This will create the greater value to their customer. WEW Solution offers unique value to their customer through e-cycle system. As a solution for these issue WEW Solution has come up with this innovative and eco-friendly product designs. Not only that these are very attractive in nature also.

### **Channels**

Our main channel of distribution will be the vendor machine. There are 5 phases of channels.

- Awareness: We can create awareness about this e cycle products through the social media for the marketing campaign.
- Purchase: This will be based on direct marketing using our sales force.
- Delivery: We directly offer our products to customer.

### **Customer Relationships**

We keep customer relationships while doing sales. Because this is the most important factor because this product can raise the demand through previous customer experience.

### **Revenue Streams**

Revenue is generated by selling the e cycle product to the customer. That's our main income source.

### **Key Resources**

Technological proficiency: Innovative knowledge of undergraduates, guidance and assistance of lecturers of the Department of Commerce and Financial Management and technological and expertise knowledge from outside parties (electronic technician).

Financial assistance: From the Department funds for the initial development of the product prototype.

### **Key Activities**

- Idea generation
- Feasibility Study
- Sketching the basic structure
- Purchasing materials
- Develop the product
- Selling and distributing
- Creating the network with customers

### **Key Partnerships**

- Technician who assist with the circuit.  
In order to make lampshade we get a knowhow from the technician.
- Householders  
The WEW Solutions will design the various products by using the CD's which are three e-cycle products using cd's. Those are CD Spindle Earring Stand , Magazine holder using CD's, Lampshade using CD's. we offer those three product to our customer.
- Environmental authority  
Since this is an innovative product which helps to manage e-waste in a positive way (by reducing, recycling and reusing), we can build up a good partnership with Environmental authority by promoting this product as eco- friendly.



### Cost structure

This describes the most important monetary significances while we are building our gray water recycling system.

- Material cost: In our product material cost are minimum we only use circuit for lamp shade.
- Packaging cost

### *Business Model Canvas*

<b>Key Partners</b>  Technician House holders Environmental authority	<b>Key Activities</b>  Idea generation Feasibility Study Sketching the basic structure Purchasing materials Develop the product Initial test run Selling and distributing	<b>Value Proposition</b>  Fulfilling the basic requirement house holders.  Uniqueness  Eco-friendly tool	<b>Customer Relationships</b>  Customer unexpected experience	<b>Customer Segment</b>  Mass market
	<b>Key Resources</b>  Technological proficiency Financial assistance		<b>Channels</b>  Direct Marketing	
<b>Cost Structure</b>  Material cost Packaging Cost			<b>Revenue Streams</b>  Selling e-cycle product	

### Risk and issues

- Lack of awareness among house holders

Proper awareness & introductions need to be given to motivate people to use these attractive products as it is new to people.

- Probability of acceptance from target customers  
If customers did not get a proper idea about WEW Solutions they may refuse to use this and it will reduce the demand of WEW Solutions.
- Create a demand to these products.

## **Coconut Shell Lamp Shade**

*by*

*Amith Prasanna, Hashendra Perera, Kavinga Gunawickrama, Udeshka Rodrigo, Gayan Suraweera, Asantha Nanayakkara, Sewwandi Wickramarachchi, W.W.H. Randunu*

### ***Introduction***

Coconut consumption in Sri Lanka is very high in Sri Lanka. With the high usage of coconut, there are so many by-products available in the environment which can be converted as resource for making other products. Majority of the coconut by-products such as coconut shells have been utilized to make activated carbon or charcoal. However, coconut shells collected in households are throwing away as waste. Therefore, still high volume of coconut shells are dumped at household level, especially in urban areas. Since these coconut shells have not been collected are send to make charcoal or activated carbon in economical way, students of innovation and technology management have decided to manufacture an lamp shade using coconut shells. Availability of resources, simple technology, expertise knowledge & getting the maximum use of waste resources can be considered as the reasons for selecting this product. Especially we took this decision as this is an **Eco-Friendly** product.

### ***Uniqueness of the product***

Lampshades that are made from coconut shell is common in market. Not only lampshades, but there are various other products available in the market. Hence, the lampshade is not innovative product; however, our process has inventive step, which make the product innovative. Our lampshade is 100% customized according to the customer requirement, where customer can give the design and drawing the way they want the lampshade. After doing the technical feasibility analysis we make the lampshade based on the customer requirement. This will give total customer satisfaction, where he/she can get a lampshade more or less exactly as they wanted.

### ***Manufacturing process***

1. Secure the coconut upright and drill a small hole in the top. Turn the coconut upside down and drain out all the liquid inside.
2. Deconstruct the lampshade of a standard desk lamp and measure the diameter of the treaded part of the lamp. This is the size of hole that will need to be cut in the bottom of the coconut shell. Lamps can be taken apart by removing the light bulb and unscrewing the plastic conical retainer.
3. Attach a butterfly drill bit to the drill that is the diameter of the measurement taken in the last step. Secure the coconut upside down in the vice and drill through the bottom of the shell.
4. Turn the coconut the correct way up in the vice and drill another hole in the top. The diameter of this hole is purely a personal choice, but it needs to be large enough to fit a light bulb through.
5. Leave the coconut to dry outside for a couple of days so no liquid gets into the electrics of the lamp. Scrape out any coconut flesh from the inside using a spoon and rinse out with water.
6. Place the bottom end of the coconut over the threaded section of the desk lamp and screw on the plastic conical retainer. Insert the light bulb and turn on the lamp.

## ***Business Model***

### **Customer Segmentation**

Customers who seek lampshade with different designs

### ***Value Proposition***

- Customization  
Lampshades can be made based on the customer requirements
- Free delivery  
We hope to deliver the products free of charge with first 2-4km from our business premises. We will charge a reasonable price for anything beyond.
- Warranty Period  
Bulbs – 12 months  
Structure – 18 months
- Product Availability  
At the shop customers can purchase the product at any time. But if customer makes the order directly to us and through electricians they should make the order 2 days before. When customers make the order they have pay an advance of 20%.
- Technology  
As you are aware the advancement of technology is very high in the modern days. But the technology for making our product is quite simple. But the expertise knowledge is required in preparing this product. The technology used can be explained in a detailed form as follows; (The method mentioned below can be changed in accordance with the type of products)

### **Potential channels**

In our distribution process our company is the main part of that process, and we directly distribute to our customers. That is one of distribution channel, and we go with our intimidators like

electricians and electrical shops. By using those intimidators we distribute our products to customers.

### ***Customer Relationships***

- On time delivery  
As customer request we ready to deliver the product to the customer on time.
- Discounts to be offered for customers who are willing to purchase both products at once.  
If customer purchases both the table lamp and ceiling lamp we provide 5% discount
- Hire purchasing system (with credit card)  
If customer wants to purchase our products in hire purchasing system they have to pay for the products by using credit cards, then customer can settle their credit purchase by paying installments to their credit cards issued financial institution.

### ***Revenue Stream***

- Sales  
Our main revenue stream would be sales.

### ***Key Resources***

- Technician  
One of the main key resources in our business is the Technician. He is the person who produces these products.
- Materials  
We needs following things
- Coconut shell  
We need several types of materials to produce our product in that materials coconut shells are one type of major material. We make some designs to the coconut shell and need 05 coconut shell to produce one product of ceiling lamp.

In our second product we need one coconut shell to produce a lamp shade. We use design coconut shell to produce our second product.

- LED bulbs  
In our ceiling lamp we need 05 LED bulbs to make our main product. And we need another one LED bulb for make lamp shade.
- Cable wires  
Product needs 5 meters of cable wires.
- Technology  
Proper technology should be used to produce this product in a proper manner as mentioned above.
- Warehouse  
we rent a warehouse for our production needs
- Network

#### ***Key Activities***

- We supply materials to the technician  
Supply coconut shell,LED bulbs,wires
- Distribute to the customers

#### ***Key Partners***

- Coconut shell suppliers  
We have to identify quality coconut shell suppliers
- Financial company  
We make an agreement with the financial company to sell our products with the system of hire purchasing by using customer credit cards.
- Insurance company  
We insure our products, because, there is a risk of our product transportation, when we transport our products to warehouse or to customer there is a risk of product damage. Because of that we have to go with an insurance

policy and we can cover our warranty value also through our insurance policy.

- Technician  
we have an agreement with technician for produce these products
- Electrical shop  
We supply our products for these targeted and well known electrical shops.
- Electricians

### ***Cost Structure***

- Initial cost
  1. Insurance fee

Insurance fee is important to reduce the risk of business function and stock firing, theft or natural disasters etc. It is an initial cost for the company because we have to incur insurance cost because company cannot expect cost for the above risks. Because of that company have to pay insurance fee as an initial cost.

2. Warehouse rent

A certain place should have for maintaining stocks and materials. As company we at the initial stage of business. Because of that company cannot produce or purchase a warehouse then we have to get a warehouse for rent basis. That rent also an initial cost for the company.



### 3. Equipment

The specific equipment are required producing and assembling these products. In our business we need some specific few equipment, which are less expensive but we have to incur some cost to the equipment.

- **Materials**

One of the main cost elements in business are materials. In our materials we have some major things like, coconut shells, LED bulbs and structure of ceiling and table lamp etc.

- **Transport**

A cost should be included for purchase materials from the suppliers and we have to get our products from the producer as well as we have to incur transport cost for deliver the products to the customers.

- **Employee salary**

In our business we have small number of employees but we have to incur more cost for our employees. Our main employee is the person who produces our product and we have to pay nearly 1500 payment to that person. And we have another type of employees who involve as intimidators, and we have to pay commission for our intimidators, it also a cost for the business.

## Chapter 05: Conclusion and Recommendations

According to the investment climate and other matters discussed in this report, there are number of positives as well as serious negatives emerged in the RRR business sector in Sri Lanka. There are many possible measures that could be taken in order to establish an attractive investment climate in RRR business, which will need substantial changes in socio- economic thinking on SWM and RRR activities. Summary of the conclusive SWOT analysis of the overall picture of the investment climate for RRR business in Sri Lanka are as follows.



- There are increasing number of Recycling facilities available
- Private sector involvement in back end RRR business activities
- There is well established regulatory framework in the country
- There is national level acceptance for RRR business
- Strong international commitment and support for RRR business in Sri Lanka



- RRR business Supply chain was not clearly identified
- Demand for RRR business outcome product was never considered as essential
- There is no strong relationship between supply chain members
- Serious manpower shortage in the industry
- There are no incentives for private sector involvement in RRR
- LAs have no technical knowledge and manpower for engaged in back end RRR activities such as recycling
- Financial institutions have no financial tools specific for RRR businesses in Sri Lanka
- There is not enough land space for RRR business in municipal areas



- To establish a RRR business supply chain consortia for collective effort
- To establish new financial tools by banks and other financial institutes
- To create service providing institutions and supporting services for RRR businesses
- To reduce the manufacturing cost of production of papers, plastics and glass products using recyclables
- To establish employment opportunities in different stages of RRR supply chain in the country



- uncontrolled imports of products related to RRR business products
- Uncontrolled export of recyclable waste recovery as raw materials rather than adding value
- Social restrictions on RRR business as lower level employment in the country
- Tax policy is not encouraging RRR business as expected
- Business thinking, awareness and respect is not encouraging RRR business in Sri Lanka
- Reduction of dumping land areas

## **Recommendations for creating healthy Investment climate**

### ***Still the customers are the king: Demand for RRR products should be created***

In the efforts in cultivating business thinking, it is essential to inculcate the demand-supply mechanism into RRR business. Therefore, dependency and interconnectivity of each stage of the RRR business process should understand as a supply chain. In a supply chain, demand for outputs of later stages determines the demand for earlier stages. Ultimately there should be demand from end users for organic foods, bio gas and also for products that use recycled materials. Even though concern for green products is very high, it is not only the public concern or sympathy about the environment. Create demand for a product is the public willingness to buy and pay a premium to consume green/cleaner products. If the consumers are not willing to pay on RRR products there will not be a sustainable RRR business, which attract private sector investments.

### ***Look at the big picture: look at the RRR supply chain as a whole***

In order to create sustainable demand for each stage supply chain member, proper marketing of RRR final products is essential. Concepts such as “green products”, “sustainability”, “and Healthy life” should be transferred to general public and should create an enthusiasm on consuming green products. When the demand for final product increases, the final product price goes up. When the price for final product goes up, upfront RRR business activities gets high demand and hence increase their prices. When there is demand growing market, entrepreneurs will seek for more efficient processing, more employees and further since there is a potential, new investors will enter to the business. Then the RRR supporting services, and financial facilities will be created to support the RRR business in Sri Lanka.

### ***Who is the boss? Listen to the voice of manufacturers***

Plastic, paper, glass and metal manufactures are the users of recycled materials. They determine the value adding demand for recyclable materials in Sri Lanka. Use of recycled materials give substantial operational and financial benefits for them. Hence, they are encouraging the RRR business in Sri Lanka. However, there is hardly any attention paid on them in the discussions of RRR business in Sri Lanka. Since they are the ones who are experts in the business they should be able to give valuable throughput for RRR business thinking efforts in Sri Lanka. Further, recognition given to those manufacturers as the key players in RRR supply chain can be used to help small scale RRR suppliers to get short-term financial facilities from banks.

***Banking for 21<sup>st</sup> Century: Introduce Supply Chain Finance (SCF) as a Tool***

When it comes to lending, Sri Lankan financial industry have traditional risk averse thinking. Before giving a loan, they want to secure the repayment through securities. This has created the attitude that “Only the people have money get loans” among business industry. This practice has a serious effect on the RRR businesses where private sector involvement is micro or small scale. Micro finance facilities are good initiatives, but commercial banks should be encouraged to come up with financial products that encourage the micro and small scale entrepreneurs in RRR business.

The concept of SCF is an initiative where finance provider and a large company under which the financier agrees to advance short-term funding against invoices issued by the large company's suppliers when these have been formally approved for payment. In this system approved suppliers' invoices are considered as the security for financiers. Since financiers have good financial relationship with banks their suppliers can get short term loans from the bank. This arrangement provides the advantages to supplier, customer and financier.

***Documentary requirements for finance should be revisited***

There is a list of statutory documents required to be submitted to get financial support for RRR business. Both private sector as well as LAs need to provide these documents to get financial support for their SWM and RRR business activities. According to the records, even though there are enough funding, LLDF loans were not utilized by the LAs. This was a result of a complex application procedure. Hence, investors are reluctant to apply for RRR business specific financial facilities. This procedure should be revisited and normalized to make it easier and less complex.

***Non value adding recyclable scrap export should be monitored***

There are number of private sector companies, especially in CMC area which buy plastic, iron, electronic and paper waste and directly export them for other countries. Even though, this might generate foreign income, they should not be given the priority when there is a local capacity to manufacture products using recycle materials. When the manufacturers invest money in recycling facilities, equipment and technologies they should get enough supply of scrap materials. If direct exporters start exporting scrap in large quantities without any resistance, it will be a blow for manufacturers who add value for scrap materials. Hence, other than e-waste other waste exports should be monitored and regulated.

***SWM or RRR business law should be established***

Currently laws relating to SWM and RRR businesses are scattered and in certain case quite old. Legal framework of SWM and RRR business should be revisited and integrate all the diverse legal recommendations as one set of clearly defined legal rules and regulations for RRR business.

***Motivating RRR business employees***

Promotional campaigns should value the role played by the RRR business employees. They should be given social security and recognition, incentives and due attention in the society. Salaries,

price for scrap have to be monitored to stop exploiting their efforts. Majority of the young people who are going for foreign employment are engaged in gardening, solid waste and sanitary sectors in other countries. Thus proper training, education and uniforms given to the workers to improve their self-esteem and enthusiasm in engaging in RRR business in Sri Lanka would definitely increase the engagement of individuals in this field.

#### **Scarcity of waste have impact on RRR business**

When considering the components of MSW, organic waste represent 60-70% of the waste and all other types contains 40-30%. But when it comes to business value, other waste are more attractive than organic waste. Even though the E-waste represent small proportion of MSW, the environmental impact and value of the recovered resources are much higher. Story is the same with other low proportionate waste like copper, iron, plastic, glass, and paper. High value might determine due to their scarcity and need of the extra effort to recover them. Hence, RRR business need to identify these scare waste types for recycling and recovery as cash cows for gain profit and then reinvest in organic waste recycling which is not financially beneficial as scare waste.

## End Notes

---

<sup>1</sup> Department of National planning, Ministry of Finance and Planning (2014) *Unstoppable Sri Lanka 2020* Public Investment Strategy 2014-2016

<sup>2</sup> UNDP (2014) *Human Development Report 2014*

<sup>3</sup> Department of National planning, Ministry of Finance and Planning (2014) *Unstoppable Sri Lanka 2020* Public Investment Strategy 2014-2016

<sup>4</sup> Statistics provided by World Health Organization. Available at <http://www.who.int/countries/lka/en/>

<sup>5</sup> Ministry of Environment & Natural Resources (2005) *Database of Municipal Solid Waste in Sri Lanka*. Battaramulla, MENR

<sup>6</sup> NSWMSC(2007) *National Solid Waste Management Status Report 2007*, Colombo, NSWMSC

<sup>7</sup> NSWMSC (2013) *Annual Report 2013*, Colombo, NSWMSC

<sup>8</sup> According to the UNCEF definition **improved sanitation facilities are the** Facilities that ensure hygienic separation of human excreta from human contact. They include:

- Flush or pour-flush toilet/latrine to:
- piped sewer system
- septic tank
- pit latrine
- Ventilated improved pit (VIP) latrine
- Pit latrine with slab
- Composting toilet. Source:

[http://www.unicef.org/wcaro/overview\\_2570.html](http://www.unicef.org/wcaro/overview_2570.html)

<sup>9</sup> Data bank of the World Bank 2014 available at <http://data.worldbank.org/indicator/SH.STA.ACSN/countries/1W-LK-8S?display=default>

<sup>10</sup> Ministry of Urban Development, Construction & Public Utilities, Rural Water Supply & Sanitation Division (2001) *National Policy for Rural Water Supply and Sanitation Sector*, Battaramulla. Available at [http://www.nwsdbwv.org/policies/RWS\\_Policy.pdf](http://www.nwsdbwv.org/policies/RWS_Policy.pdf)

<sup>11</sup> Detail information about the SWM are included in UNEP (2005), *Solid Waste Management*, VOL 1, Geneva, UNEP

<sup>12</sup> Ali, S. M., Pervaiz, A., Afzal, B., Hamid, N., & Yasmin, A. (2014). Open dumping of municipal solid waste and its hazardous impacts on soil and vegetation diversity at waste dumping sites of Islamabad city. *Journal of King Saud University - Science*, 26(1), 59–65.  
doi:10.1016/j.jksus.2013.08.003

<sup>13</sup> United States Environmental protection agency **Resource Recovery Act (RRA) of 1970**

Available in <http://www.epa.gov/region9/waste/tribal/reg.html>

<sup>14</sup> Based on the observations and interviews conducted by researches with the market supervisor at Jathika Pola and person in charge of Meethotamulla dump yard in month of January 2014



## Bibliography

- 3R KNOWLEDGE HUB. (2014, June 28). *City Waste Profile - Kurunegala*. Retrieved from <http://www.3rkh.net/>:  
[http://www.3rkh.net/index.php?option=com\\_phocadownload&view=file&id=586:city-waste-profile-kurunegala-sri-lanka&start=35&order\\_by=ordering&Itemid=238](http://www.3rkh.net/index.php?option=com_phocadownload&view=file&id=586:city-waste-profile-kurunegala-sri-lanka&start=35&order_by=ordering&Itemid=238)
- ACCA. (2014). *Innovations in access to finance for SMEs*. London: ACCA Global.
- Central Environment Authority. (n.d.). *Technical Guidelines on Solid Waste Management in Sri Lanka*. Pollution Control Division.
- Central Environmental Authority. (1994). Review of Environmental Legislations in Sri Lanka. *Volume 01*.
- Colombo Municipal Council. (2012). *Welcome to CMC*. Retrieved Jan 5, 2015, from Colombo Municipal Council: <http://www.cmc.lk/>
- Department of Census and Statistics. (2007). *Sri Lanka Demographic and Health Survey*. Colombo: Department of Census and Statistics.
- Dilhani, J. A., De Alwis, A., & Sugathapala, T. (2011). *Biogas Production Using Market Garbage*. Retrieved from [www.energy.gov.lk](http://www.energy.gov.lk/):  
[http://www.energy.gov.lk/pdf/special\\_publications/Biogas%20Production%20Using%20Market%20Garbage.pdf](http://www.energy.gov.lk/pdf/special_publications/Biogas%20Production%20Using%20Market%20Garbage.pdf)
- District Secretariat Kurunegala. (2012). *Performance Report 2012*. Kurunegala: District Secretariat Kurunegala.
- Energy, M. o. (2007). *National Policy on Solid Waste Management*. Retrieved January 20, 2015, from [http://www.environmentmin.gov.lk/web/index.php?option=com\\_content&view=article&id=136&Itemid=127&lang=en](http://www.environmentmin.gov.lk/web/index.php?option=com_content&view=article&id=136&Itemid=127&lang=en)

- Ministry of Environment and Natural Resources. (2005). *Database of Municipal Solid Waste in Sri Lanka*. Battaramulla: MENR.
- Ministry of Finance. (2014). *A new economic order for a strong national economy: The Economic Policy Framework of Government of Sri Lanka*. Colombo: Ministry of Finance.
- Munasinghe, C. (2009). Proceedings of Workshop on National Network for An Integrated Approach to Sustainable On-Site & Decentralised Sanitation in Sri Lanka. *Workshop on National Network for An Integrated Approach to Sustainable On-Site & Decentralised Sanitation in Sri Lanka*. Colombo: Energy Forum, Sri Lanka.
- NSWMSC. (2008). *National Solid Waste Management Annual Report 2007*. Colombo: NSWMSC.
- NSWMSC. (2014). *National Solid Waste Management Annual Report*. Ministry of Local Government and Provincial.
- South Asian Conference on Sanitation. (2013). *Country Paper Sri Lanka*. Kathmandu: SACONS.
- The World Bank. (2012). *WHAT A WASTE Global review of Solid Waste Management*. Washington, DC: The World Bank.
- Tillett, T. (2013, May). Pit Latrines and Groundwater Contamination; Negative Impacts of a Popular Sanitation Method. *Environmental Health Perspectives*, 121(5), p. A169.
- UNEP. (1992). *BASEL CONVENTION ON THE CONTROL OF TRANSBOUNDARY HAZARDOUS WASTES and their disposal*. Châtelaine,: UNEP.
- UNEP. (2005). *SOLID WASTE MANAGEMENT*. UNEP.
- Urban Development Authority. (2004). *General Regulations*. Colombo: UDA.

WASPA Asia. (2006). *Background information for Kurunegala City, Sri Lanka*. Colombo: WASPA Asia.

Western Province Council. (2008 July 30). *Gazzete Number 1560/06*. Democratic Social Republic of Sri Lanka.

Western Province Council. (2012). *Statue of Preventing Public Health Nuisances of the Western Province Council No 03 of 2012*. Western Provincil Council, Sri Lanka.

WLE/IWMI. (2013). *Innovative Partnerships for Resource Recovery & Reuse (RRR)*. *2013 World Water Week*. Stockholm: WLE/IWMI.



*Organized by*



Association of Business Technology  
Department of Commerce & Financial Management (DCFM)  
University of Kelaniya